

I-93 North
Between Route 28, Charlestown, and the New Hampshire State Line

I-93 Northbound: Route 28, Somerville, to Roosevelt Circle, Medford

Route/Lane Schematics: 1977, 1987, 1999, 2005-2006, & 2010

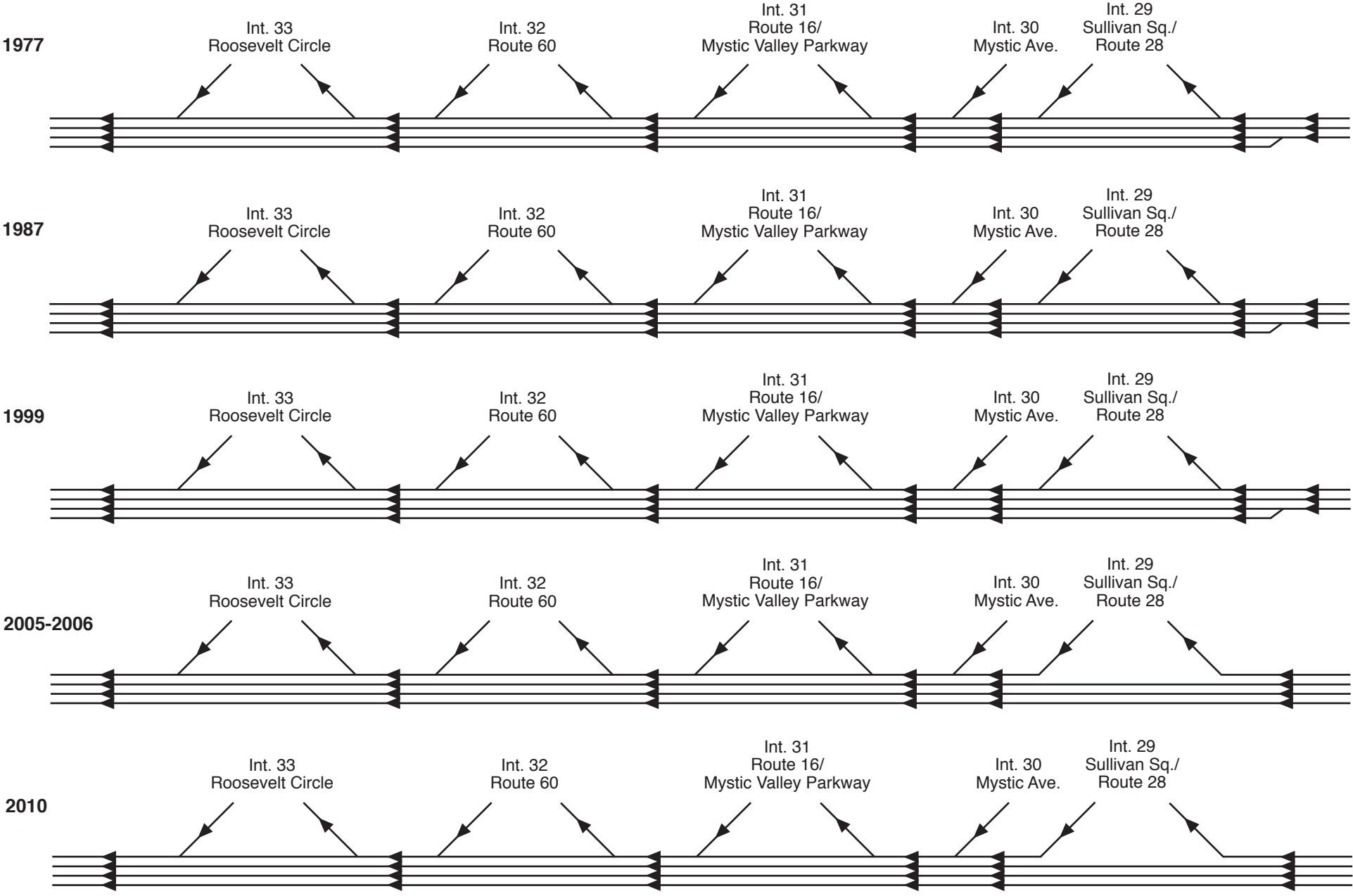

**I-93 Northbound: Route 28, Somerville, to Roosevelt Circle, Medford
AWDT Traffic Flow Diagrams: 1977, 1987, 1999, 2005-2006, & 2010**

1977 AWDT

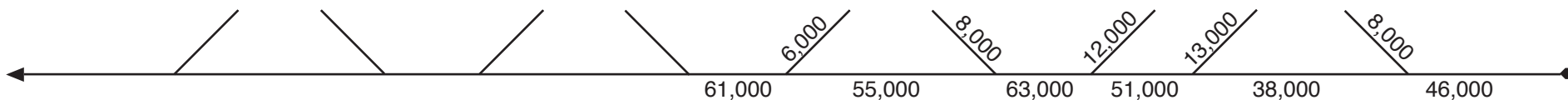

1987 AWDT

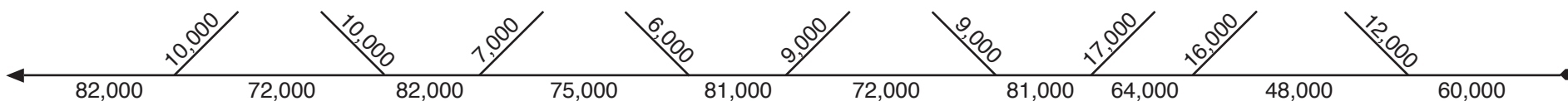

1999 AWDT

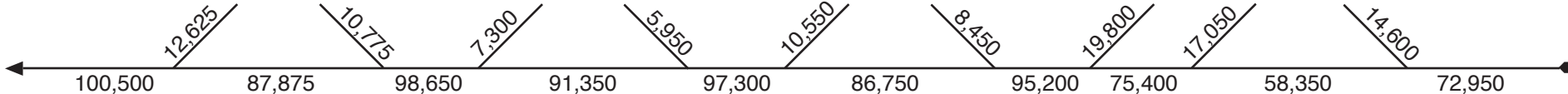

2005/2006 AWDT

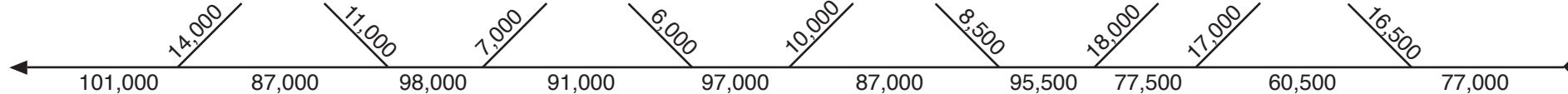

2010 AWDT

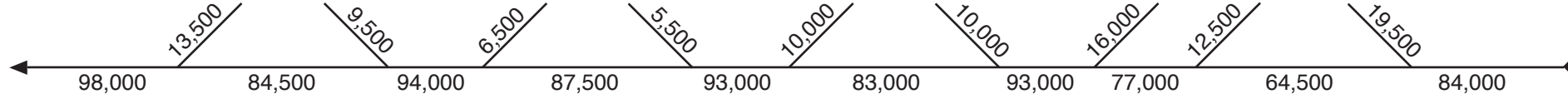

I-93 Northbound: Route 28, Somerville, to Roosevelt Circle, Medford AM Peak Period Traffic Flow Diagrams: 2010

03/11

Route/Lane Schematic

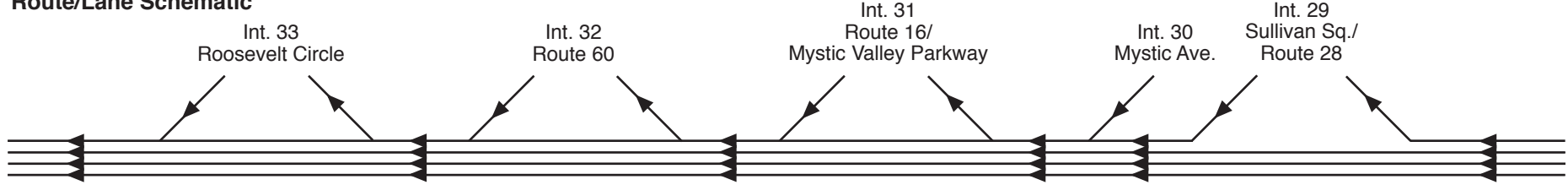

6-7 AM

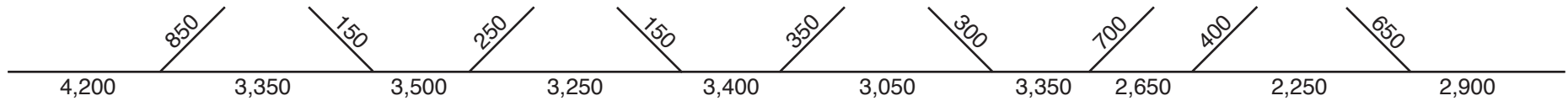

7-8 AM

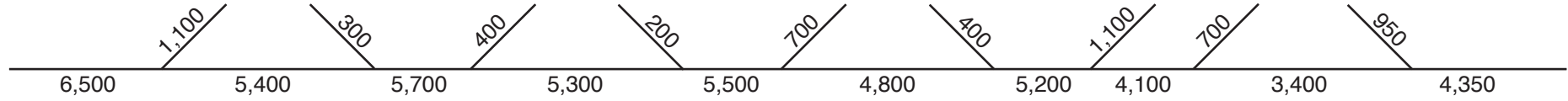

8-9 AM

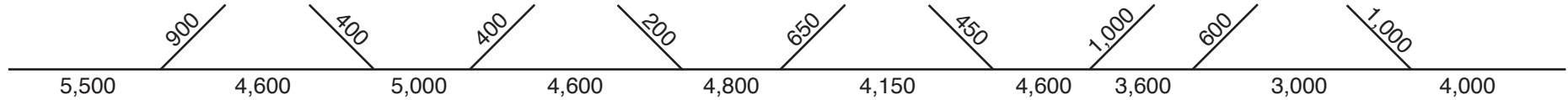

9-10 AM

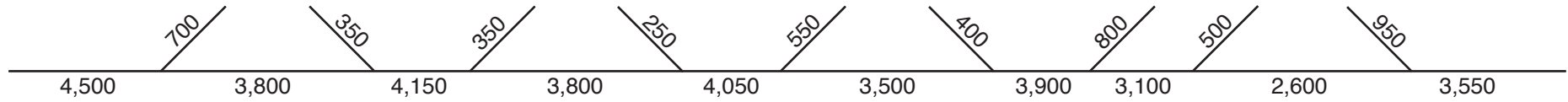

I-93 Northbound: Route 28, Somerville, to Roosevelt Circle, Medford PM Peak Period Traffic Flow Diagrams: 2010

03/11

Route/Lane Schematic

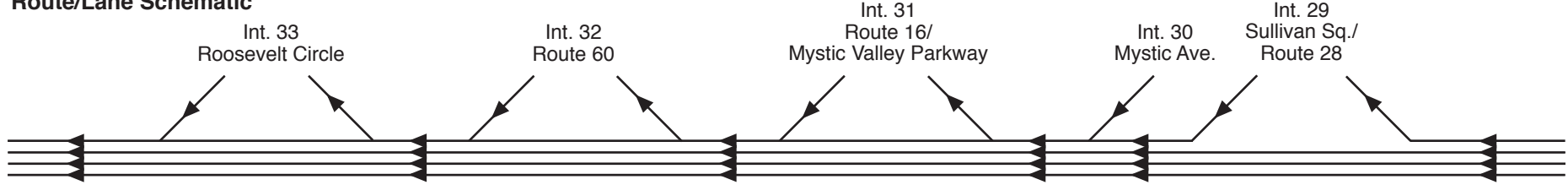

3-4 PM

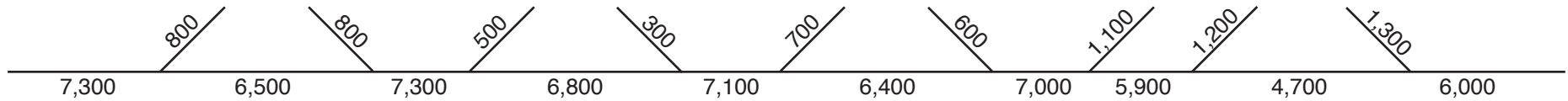

4-5 PM

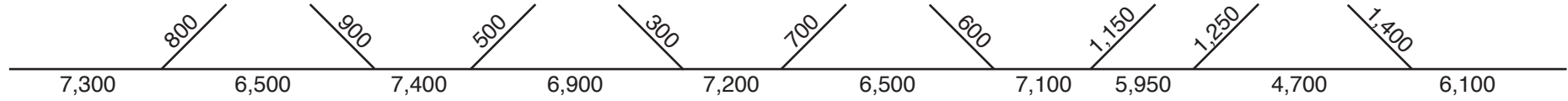

5-6 PM

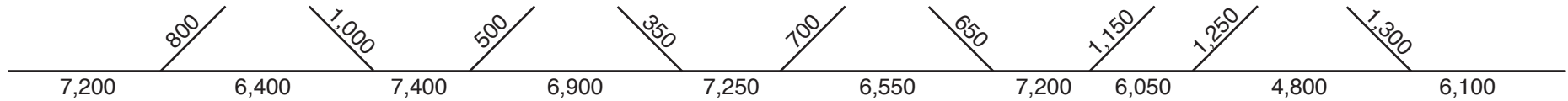

6-7 PM

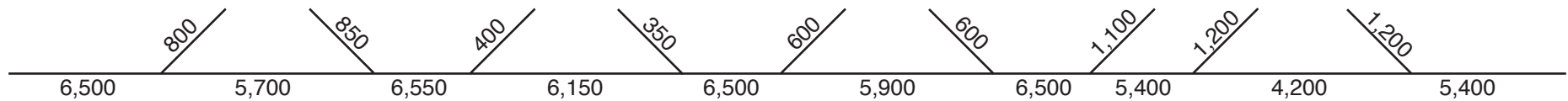

I-93 Southbound: Roosevelt Circle, Medford, to Route 28, Somerville

Route/Lane Schematics: 1977, 1987, 1999, 2005/2006, & 2010

03/11

1977

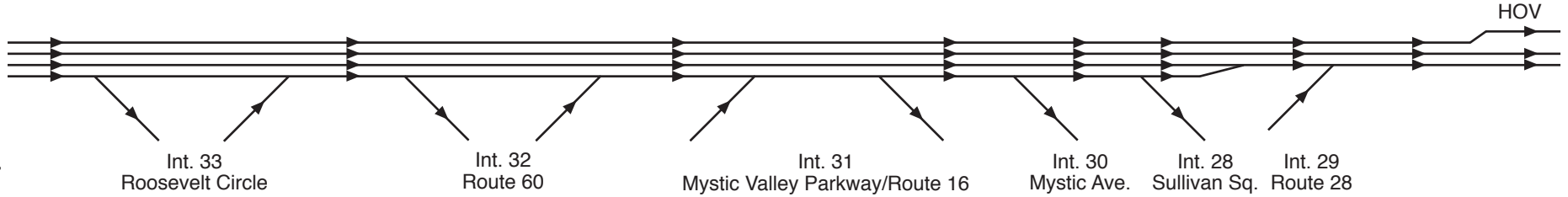

1987

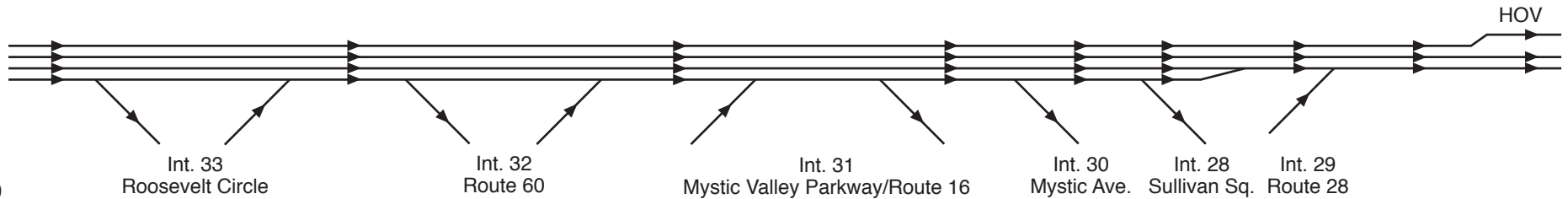

1999

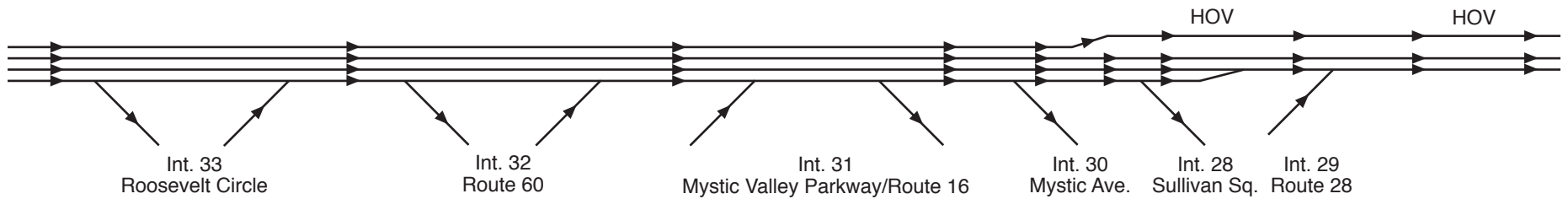

2005-2006

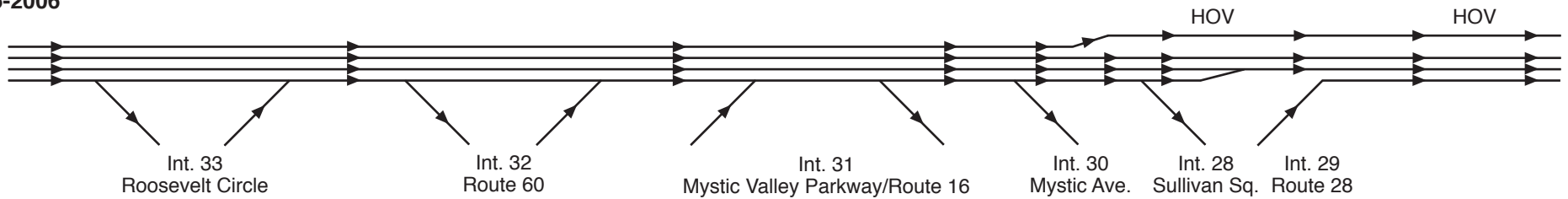

2010

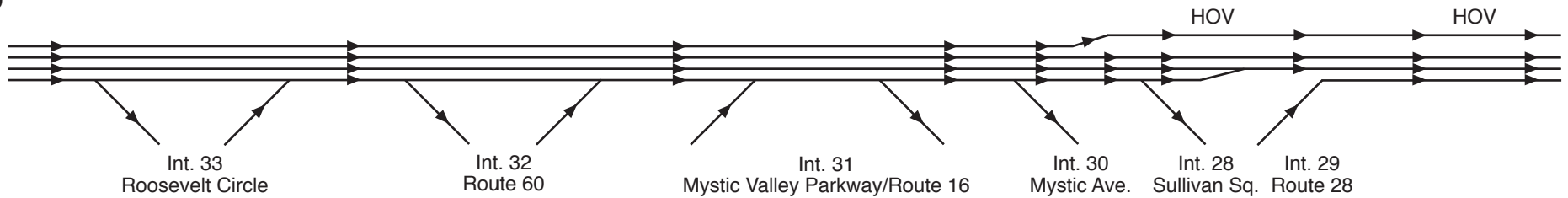

I-93 Southbound: Roosevelt Circle, Medford, to Route 28, Somerville
AWDT Traffic Flow Diagrams: 1977, 1987, 1999, 2005/2006, & 2010

1977 AWDT

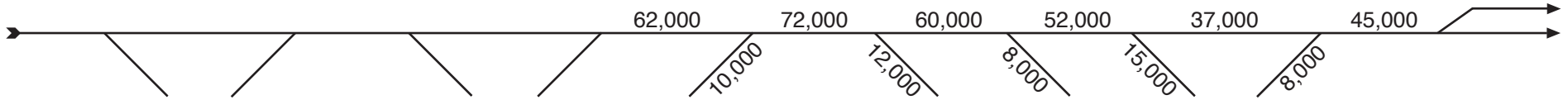

1987 AWDT

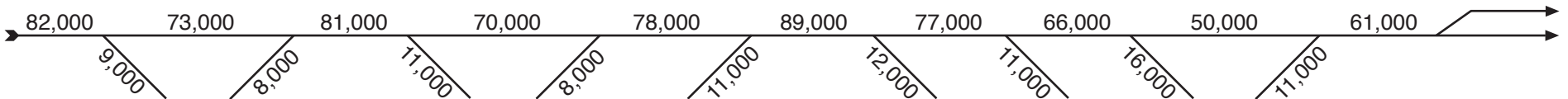

1999 AWDT

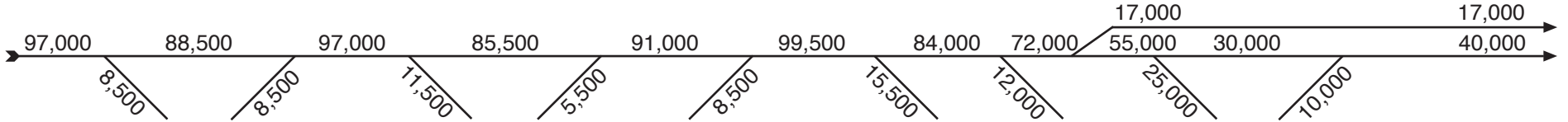

2005/2006 AWDT

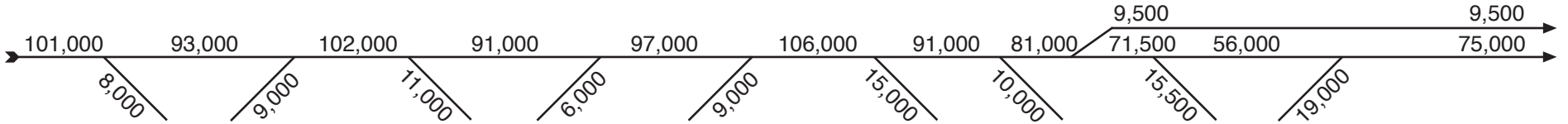

2010 AWDT

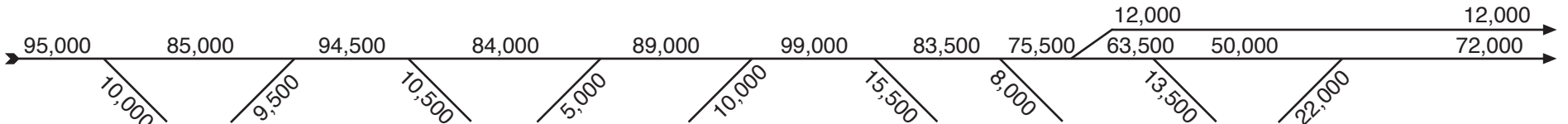

I-93 Southbound: Roosevelt Circle, Medford, to Route 28, Charlestown

AM Peak Period Traffic Flow Diagrams: 2010

03/11

Route/Lane Schematic

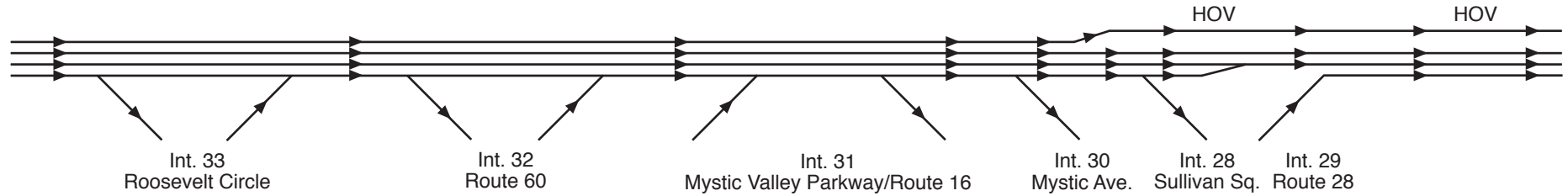

6-7 AM

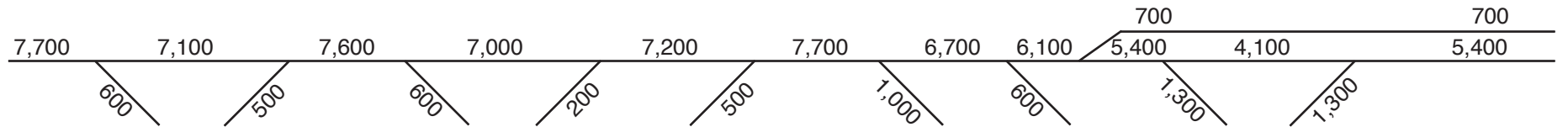

7-8 AM

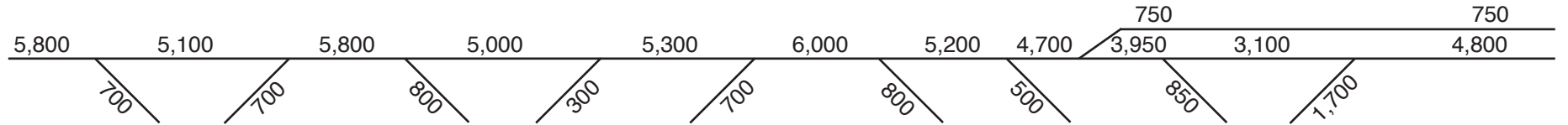

8-9 AM

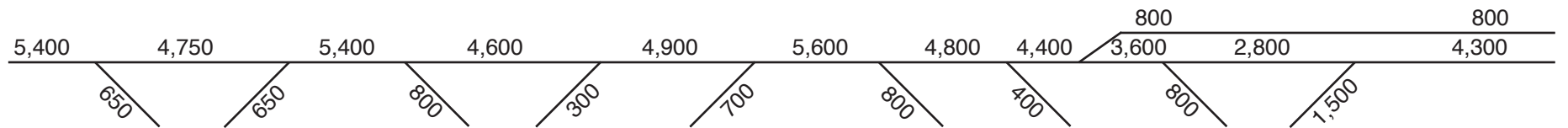

9-10 AM

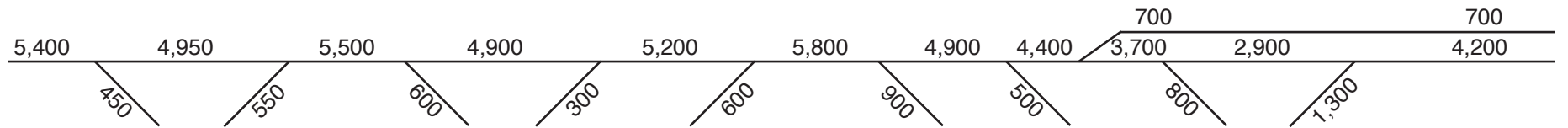

I-93 Southbound: Roosevelt Circle, Medford, to Route 28, Charlestown

PM Peak Period Traffic Flow Diagrams: 2010

Route/Lane Schematic

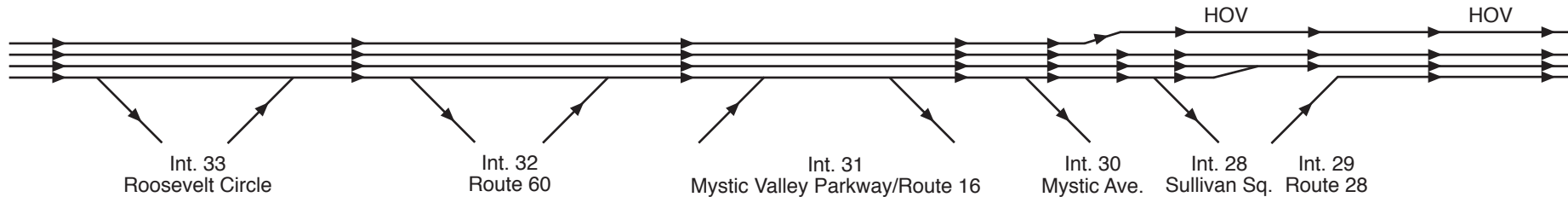

3-4 PM

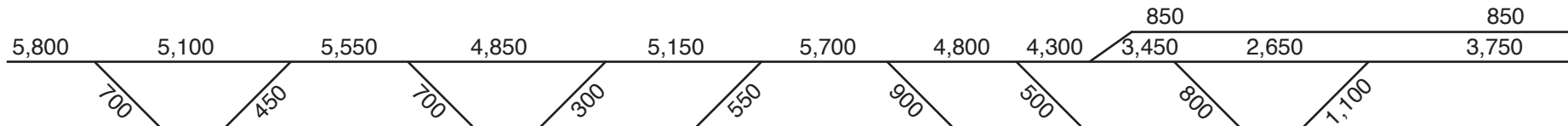

4-5 PM

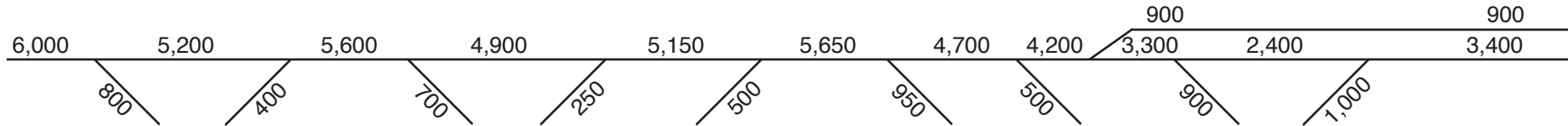

5-6 PM

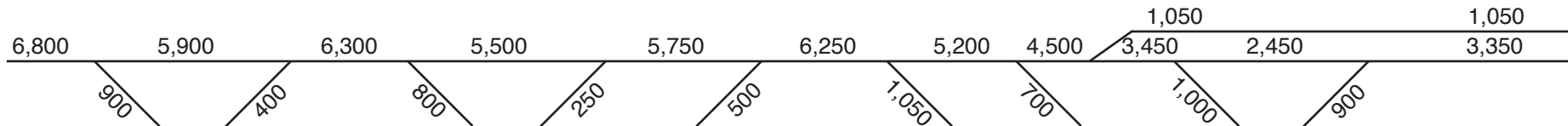

6-7 PM

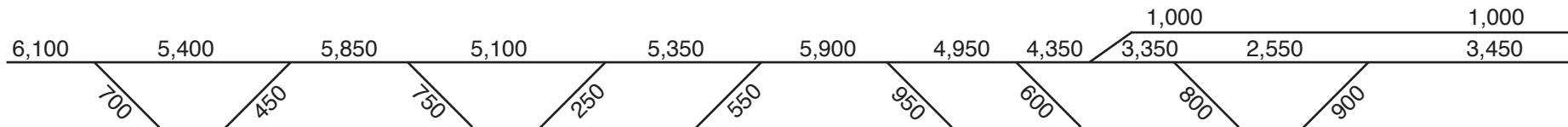

I-93 Northbound: Route 28, Stoneham, to Commerce Way, Woburn AWDT Traffic Flow Diagrams: 1999 & 2006

Route/Lane Schematic

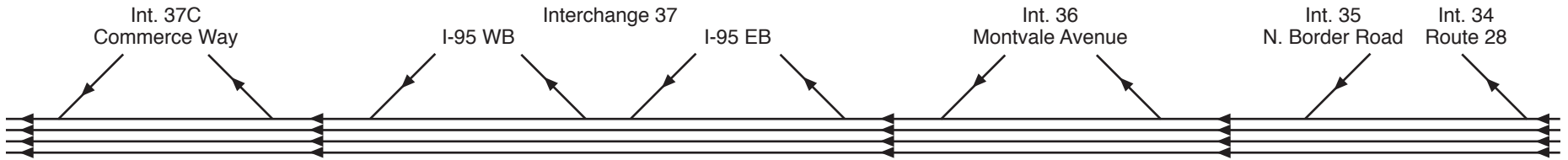

1999 AWDT

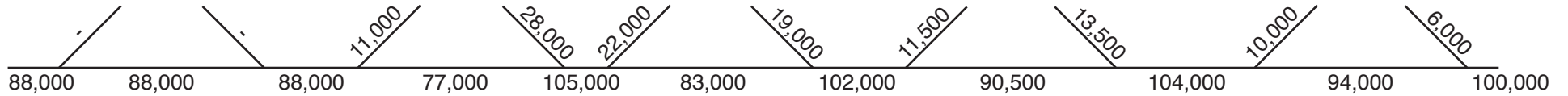

2006 AWDT

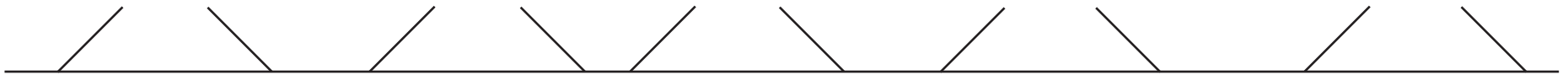
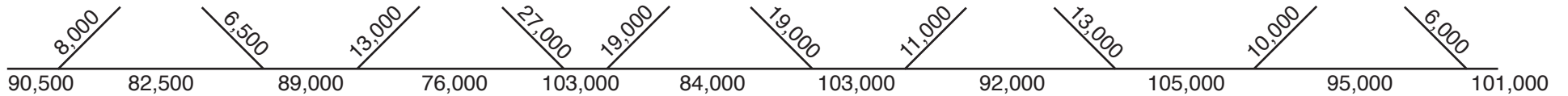

I-93 Northbound: Route 28, Stoneham, to Commerce Way, Woburn AM Peak Period Traffic Flow Diagrams: 2006

Route/Lane Schematic

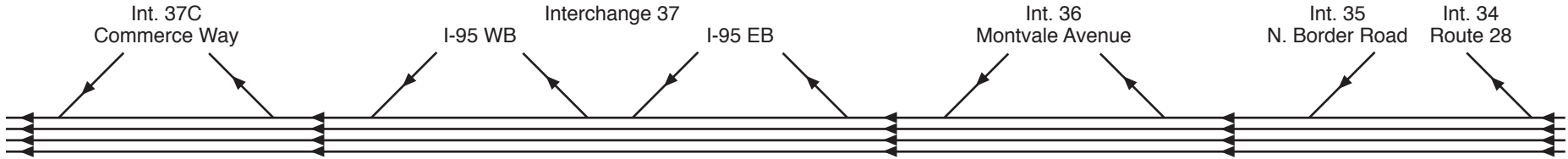

6-7 AM

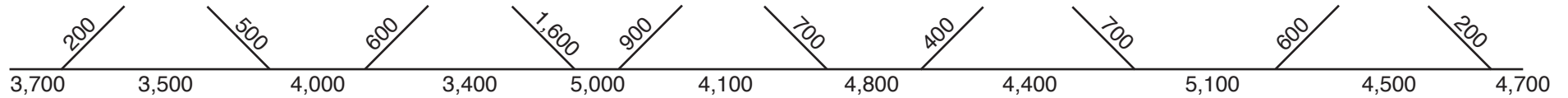

7-8 AM

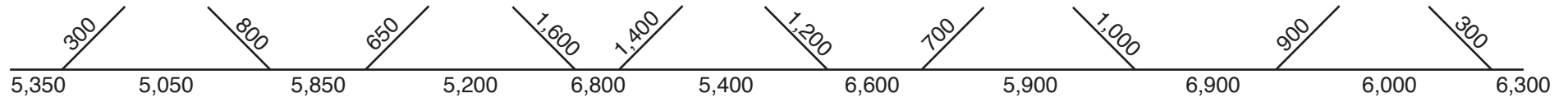

8-9 AM

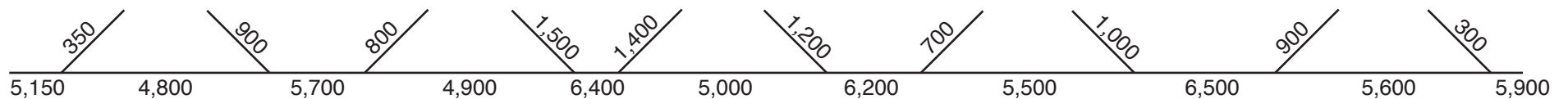

9-10 AM

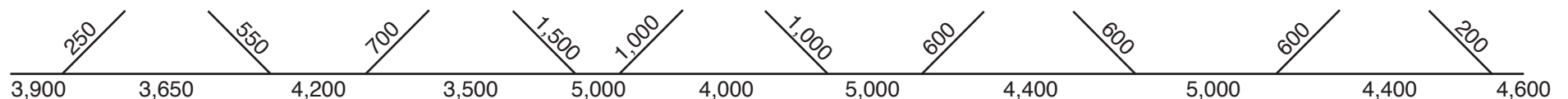

I-93 Northbound: Route 28, Stoneham, to Commerce Way, Woburn PM Peak Period Traffic Flow Diagrams: 2006

Route/Lane Schematic

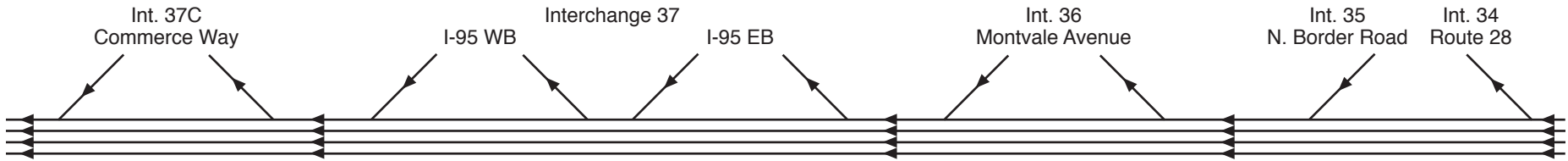

3-4 PM

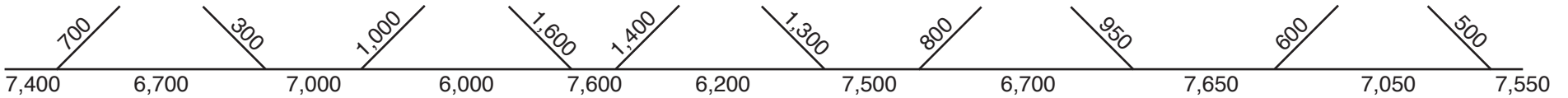

4-5 PM

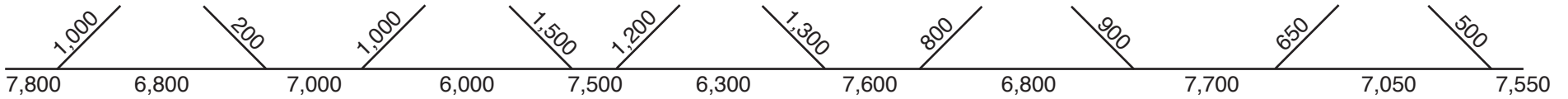

5-6 PM

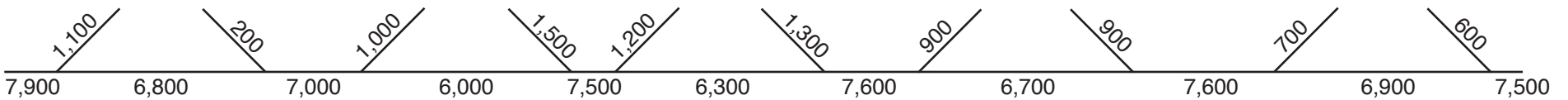

6-7 PM

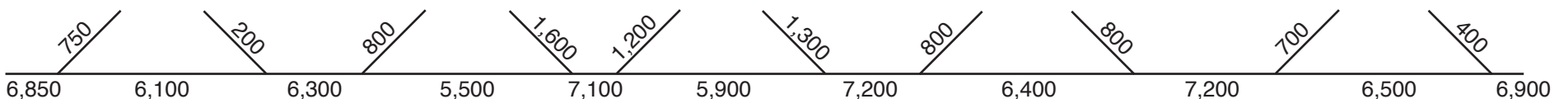

I-93 Southbound: Commerce Way, Woburn, to Route 28, Stoneham AWDT Traffic Flow Diagrams: 1999 & 2006

Route/Lane Schematic

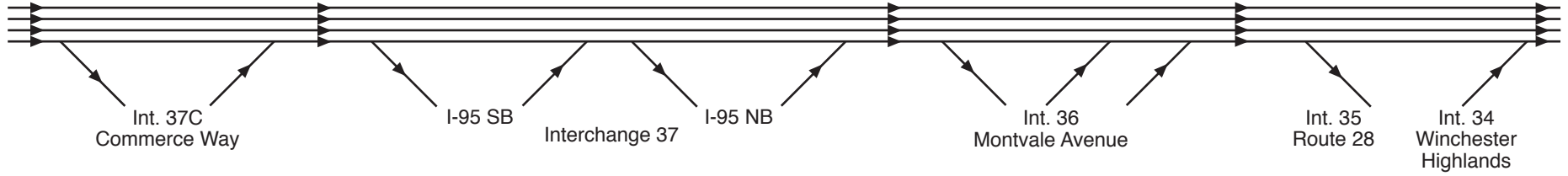

1999 AWDT

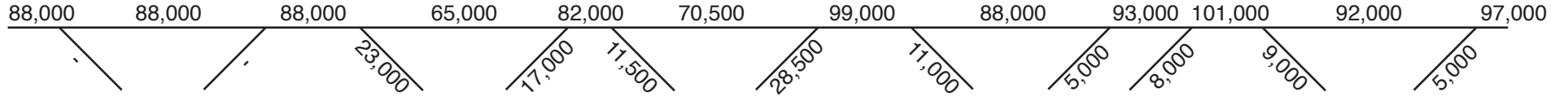

2006 AWDT

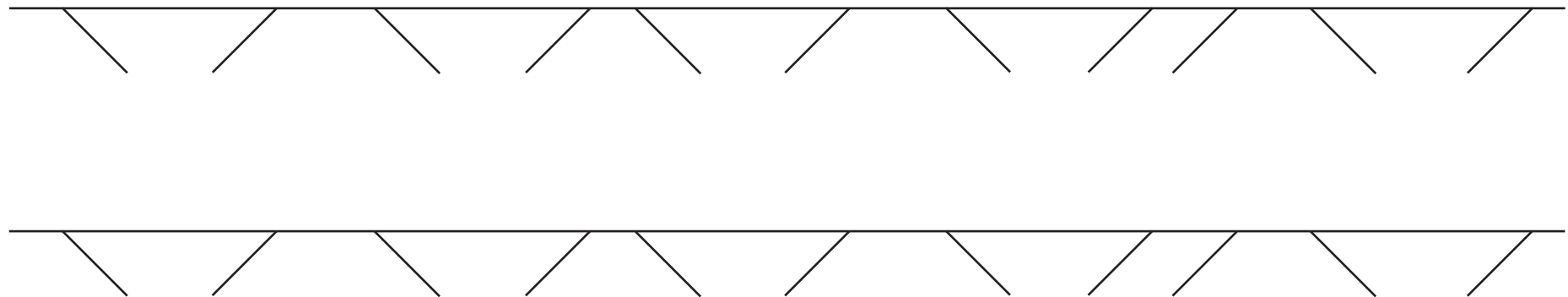
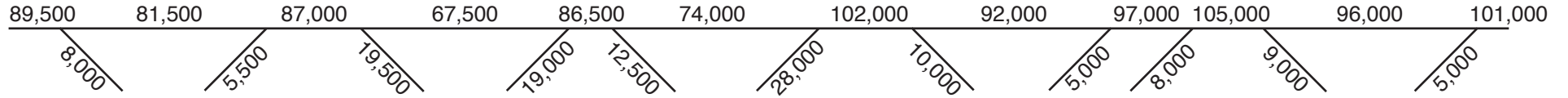

I-93 Southbound: Commerce Way, Woburn, to Route 28, Stoneham AM Peak Period Traffic Flow Diagrams: 2006

Route/Lane Schematic

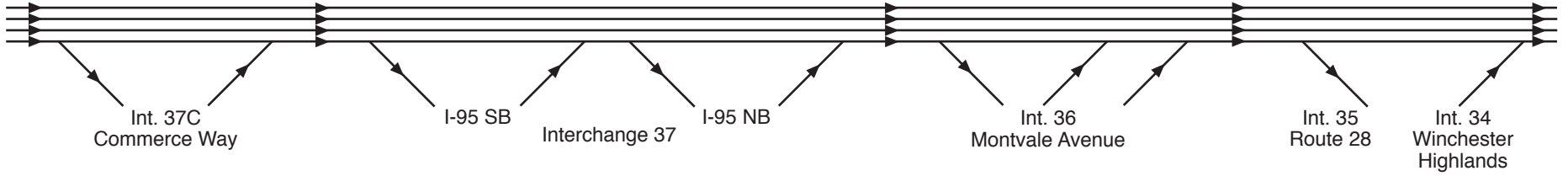

6-7 AM

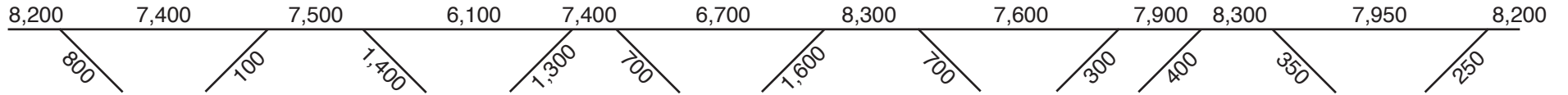

7-8 AM

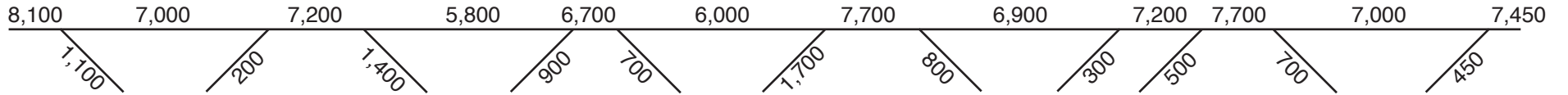

8-9 AM

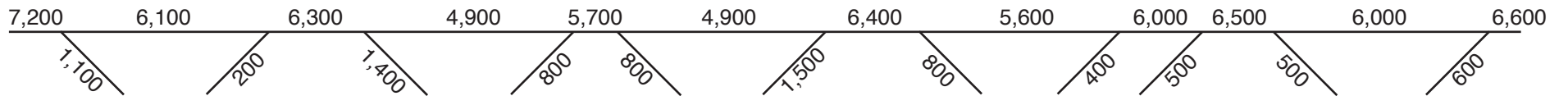

9-10 AM

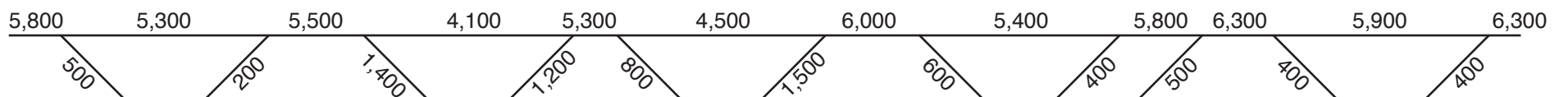

I-93 Southbound: Commerce Way, Woburn, to Route 28, Stoneham PM Peak Period Traffic Flow Diagrams: 2006

Route/Lane Schematic

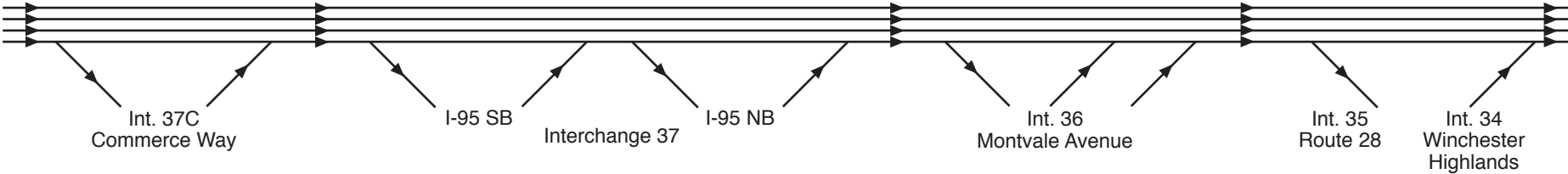

3-4 PM

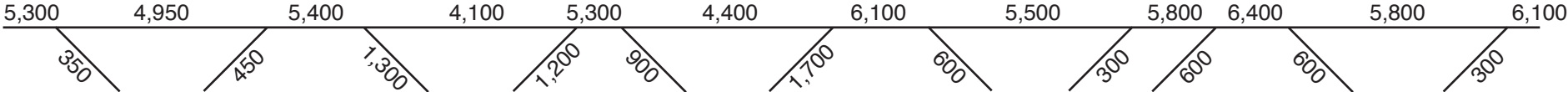

4-5 PM

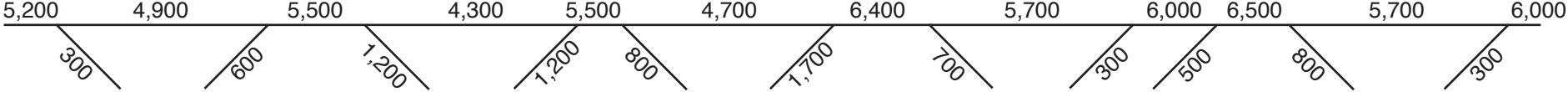

5-6 PM

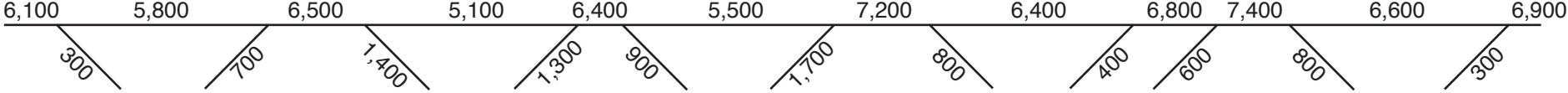

6-7 PM

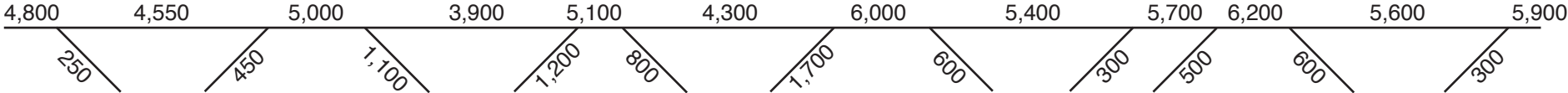

I-93 Northbound: Route 129, Wilmington, to Dascomb Road, Andover AWDT Traffic Flow Diagrams: 1999 & 2006

Route/Lane Schematic

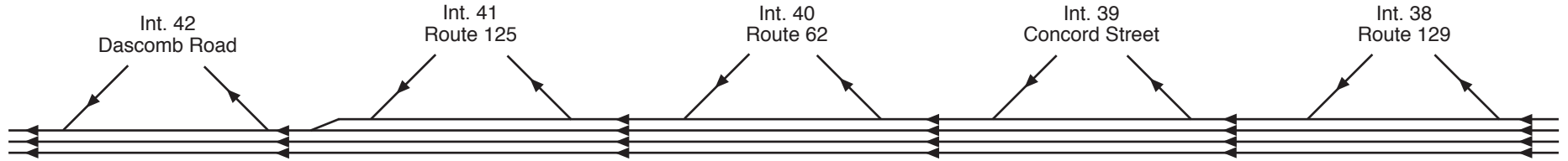

1999 AWDT

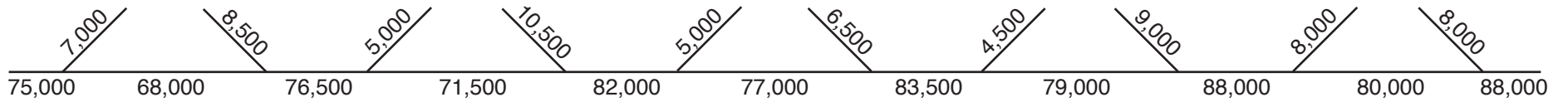

2006 AWDT

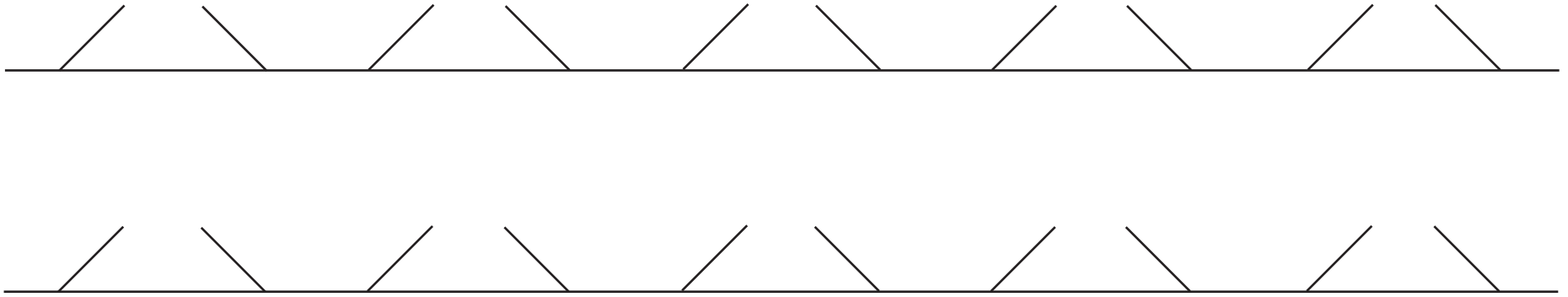
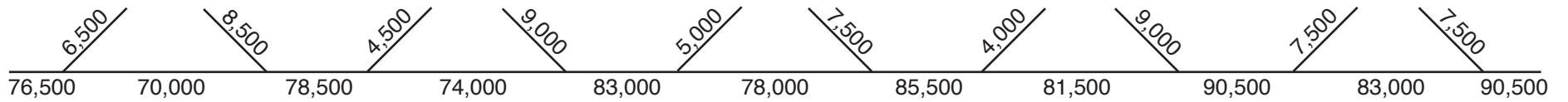

I-93 Northbound: Route 129, Wilmington, to Dascomb Road, Andover AM Peak Period Traffic Flow Diagrams: 2006

Route/Lane Schematic

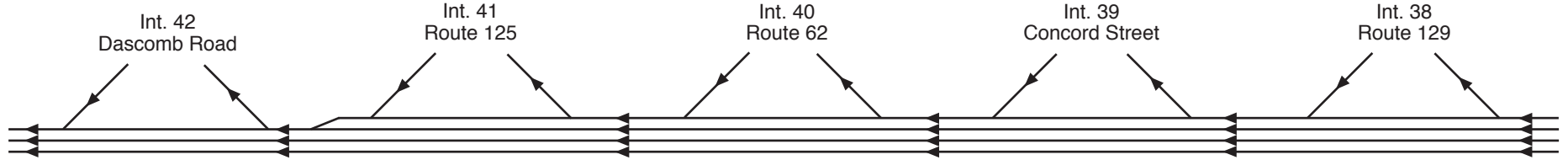

6-7 AM

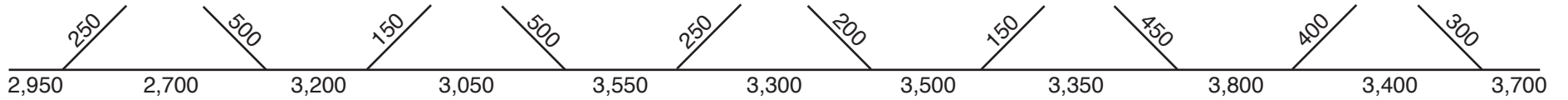

7-8 AM

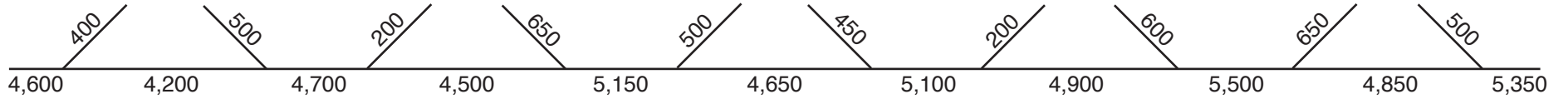

8-9 AM

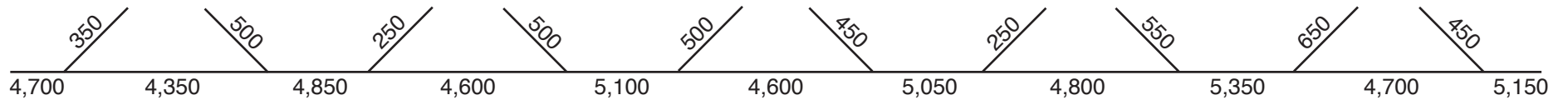

9-10 AM

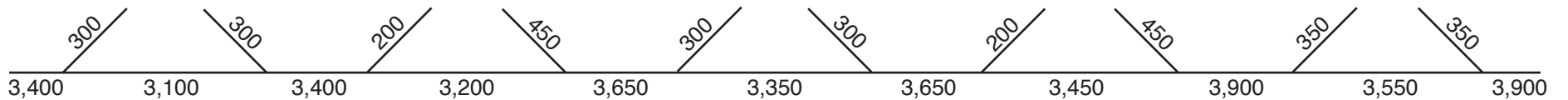

I-93 Northbound: Route 129, Wilmington, to Dascomb Road, Andover PM Peak Period Traffic Flow Diagrams: 2006

Route/Lane Schematic

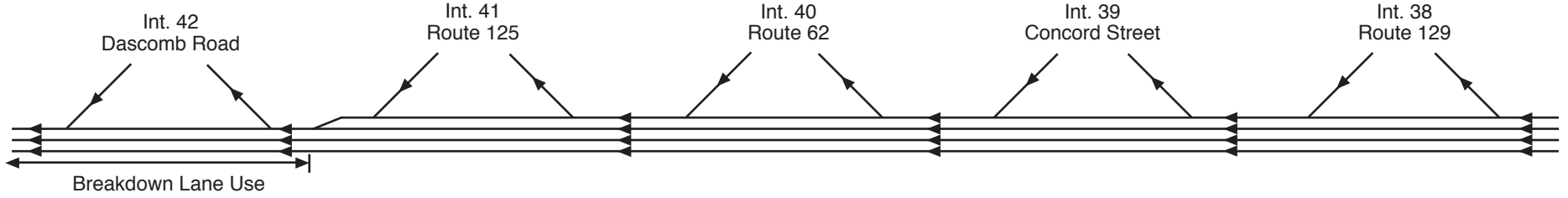

3-4 PM

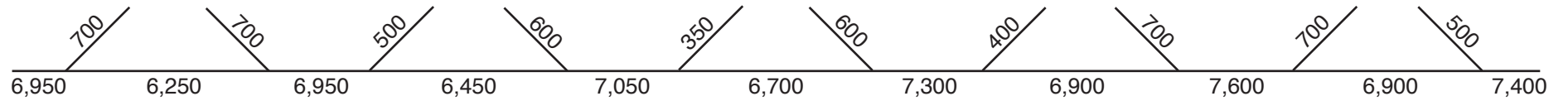

4-5 PM

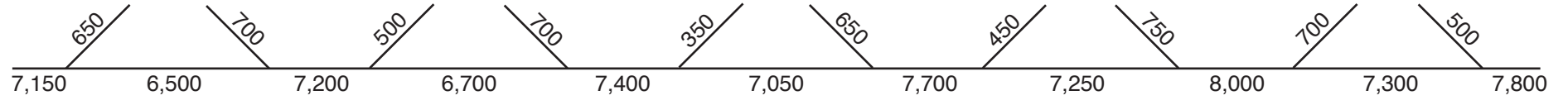

5-6 PM

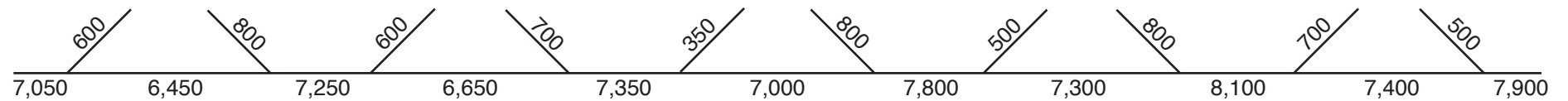

6-7 PM

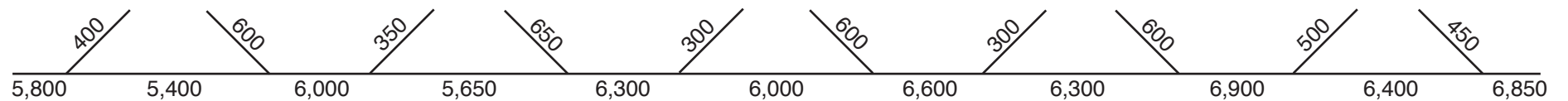

I-93 Southbound: Dascomb Road, Andover, to Route 129, Wilmington

AWDT Traffic Flow Diagrams: 1999 & 2006

Route/Lane Schematic

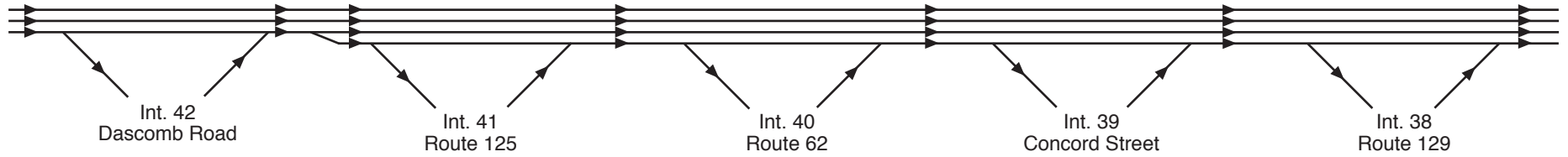

1999 AWDT

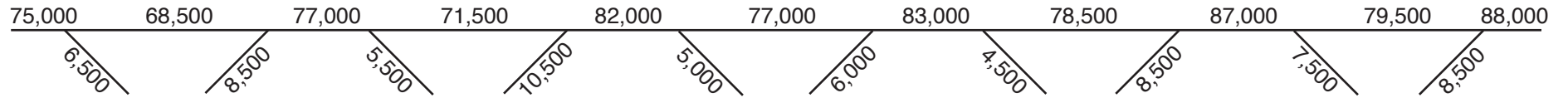

2006 AWDT

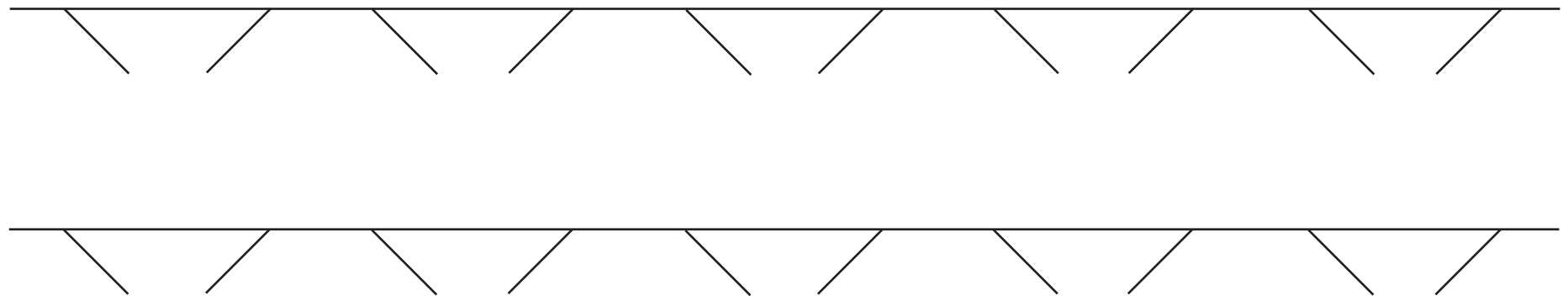
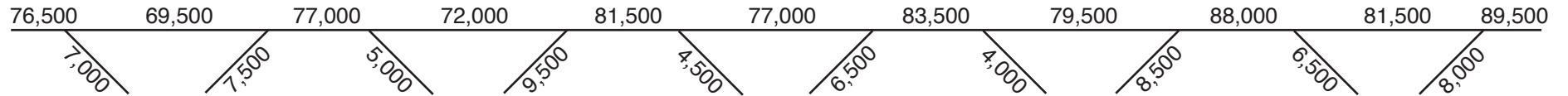

I-93 Southbound: Dascomb Road, Andover, to Route 129, Wilmington

AM Peak Period Traffic Flow Diagrams: 2006

Route/Lane Schematic

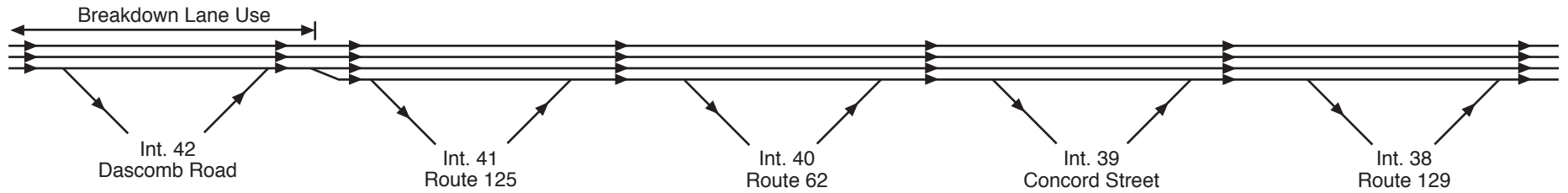

6-7 AM

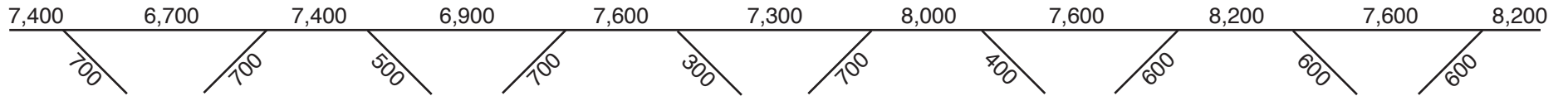

7-8 AM

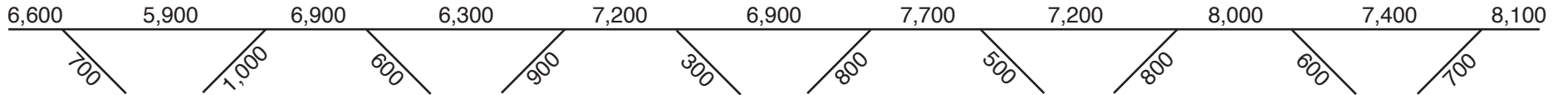

8-9 AM

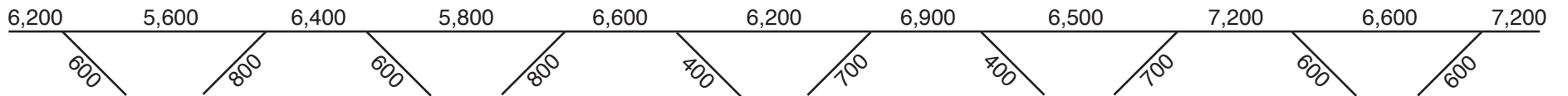

9-10 AM

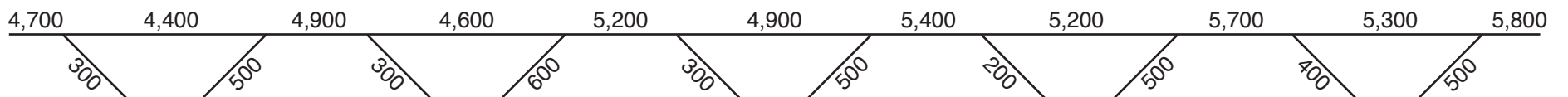

I-93 Southbound: Dascomb Road, Andover, to Route 129, Wilmington PM Peak Period Traffic Flow Diagrams: 2006

Route/Lane Schematic

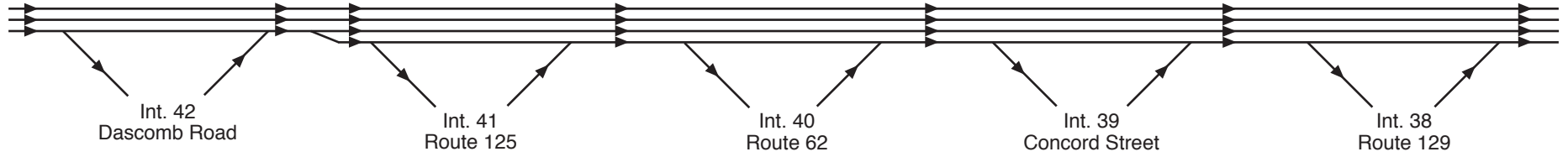

3-4 PM

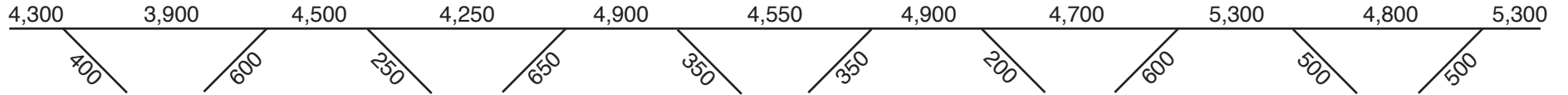

4-5 PM

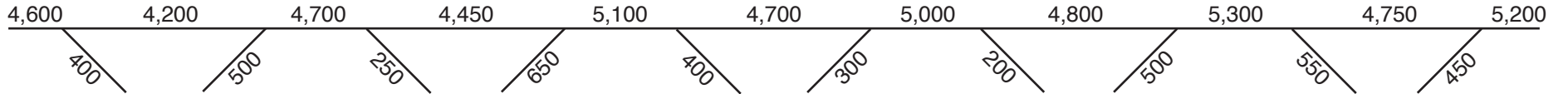

5-6 PM

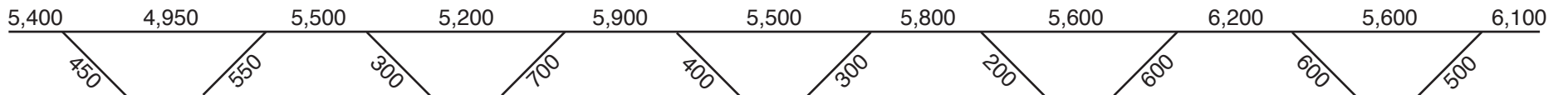

6-7 PM

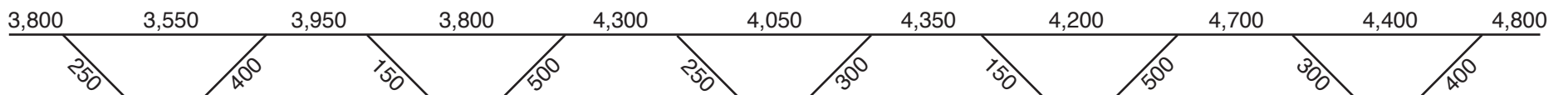

I-93 Northbound: Route 133, Andover, to River Road, Andover AWDT Traffic Flow Diagrams: 1999 & 2006

Route/Lane Schematic

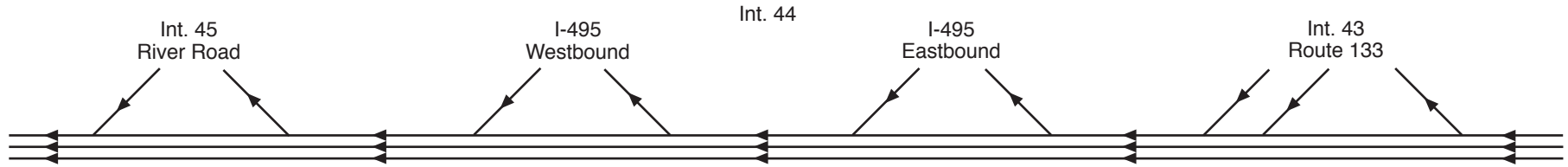

1999 AWDT

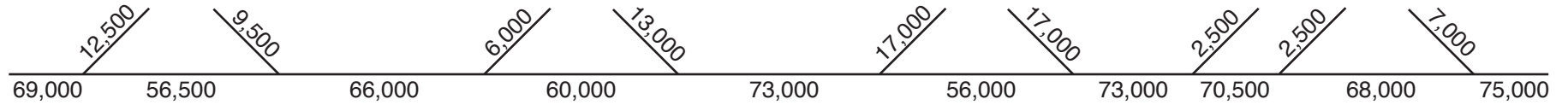

2006 AWDT

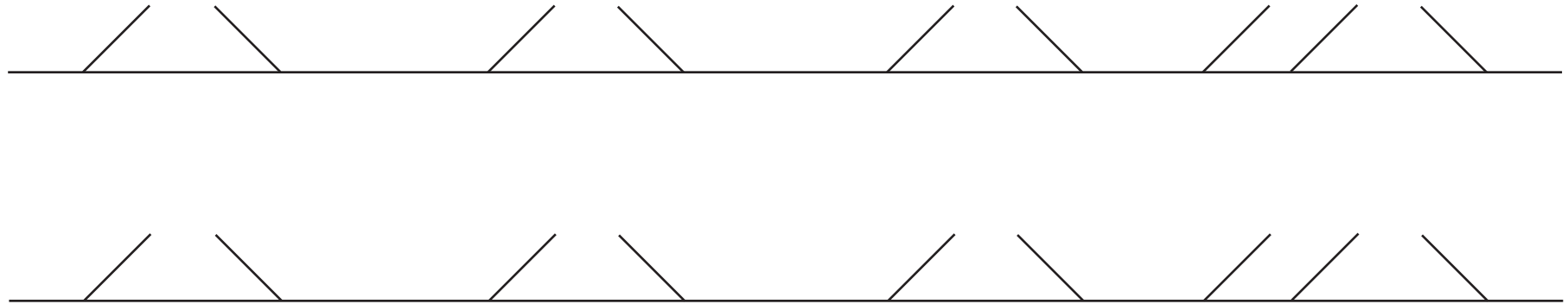

I-93 Northbound: Route 133, Andover, to River Road, Andover AM Peak Period Traffic Flow Diagrams: 2006

Route/Lane Schematic

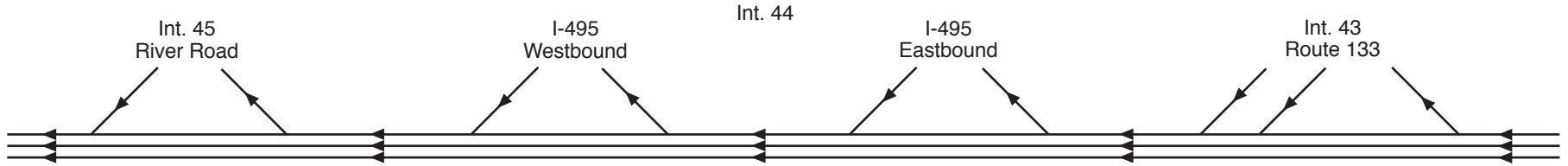

6-7 AM

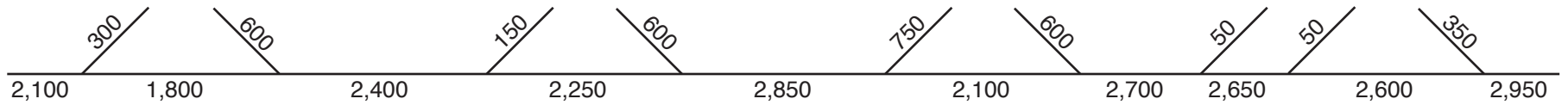

7-8 AM

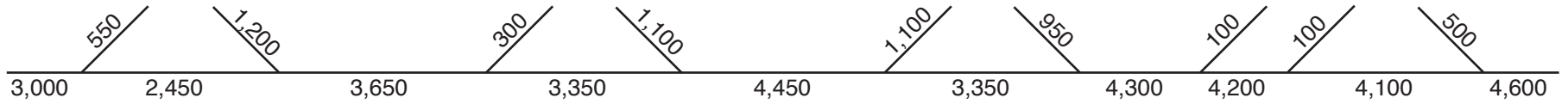

8-9 AM

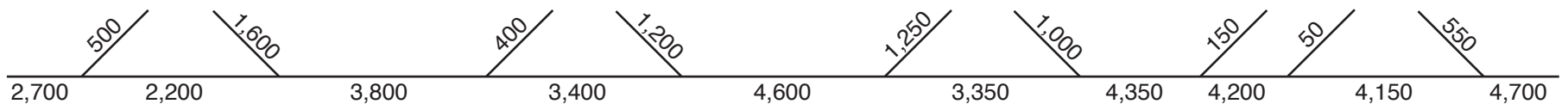

9-10 AM

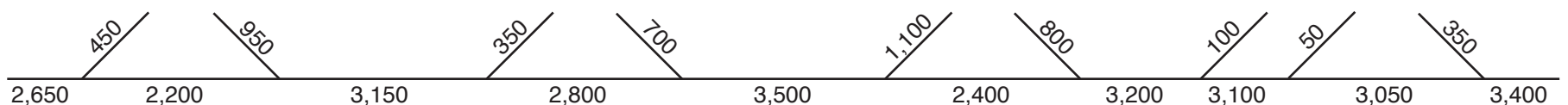

I-93 Northbound: Route 133, Andover, to River Road, Andover PM Peak Period Traffic Flow Diagrams: 2006

Route/Lane Schematic

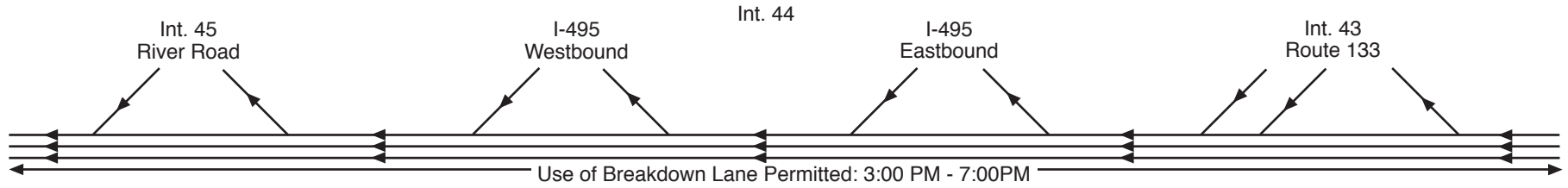

3-4 PM

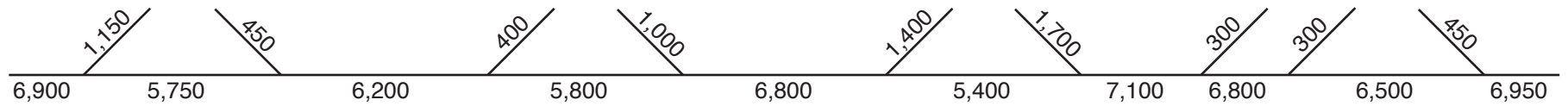

4-5 PM

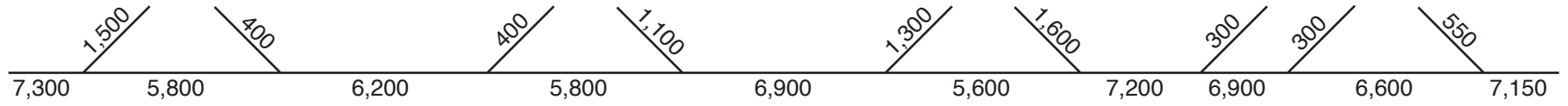

5-6 PM

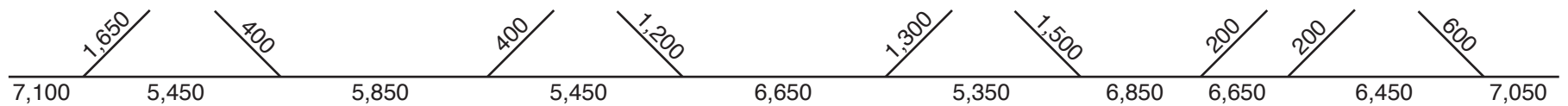

6-7 PM

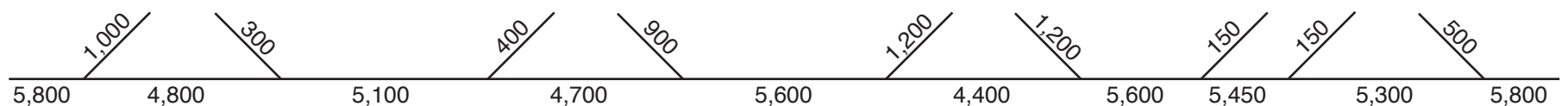

I-93 Southbound: River Road, Andover, to Route 133, Andover AWDT Traffic Flow Diagrams: 1999 & 2006

Route/Lane Schematic

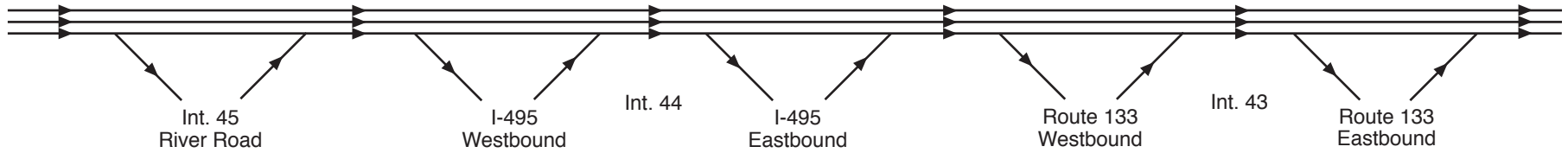

1999 AWDT

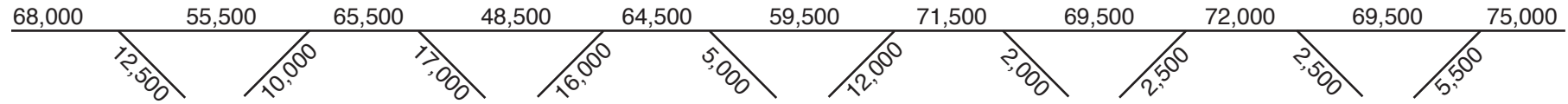

2006 AWDT

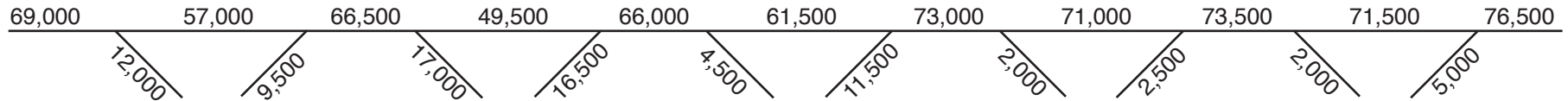

I-93 Southbound: River Road, Andover, to Route 133, Andover AM Peak Period Traffic Flow Diagrams: 2006

Route/Lane Schematic

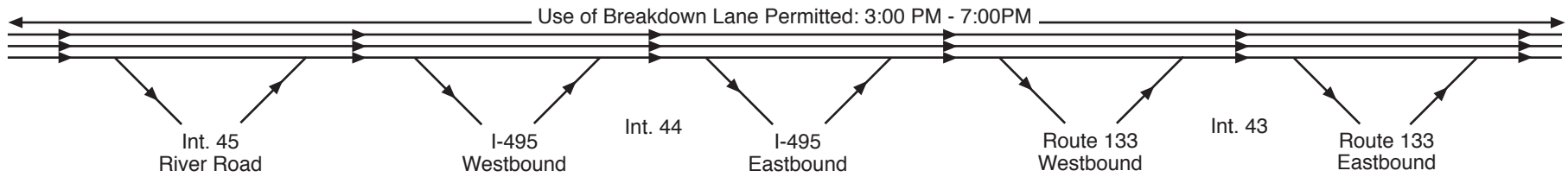

6-7 AM

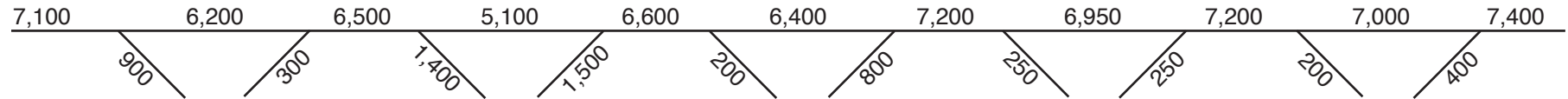

7-8 AM

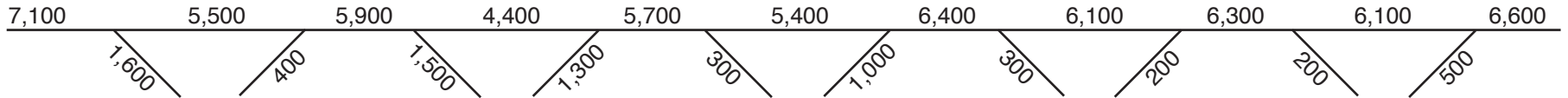

8-9 AM

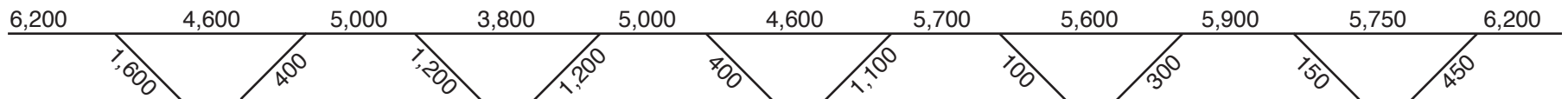

9-10 AM

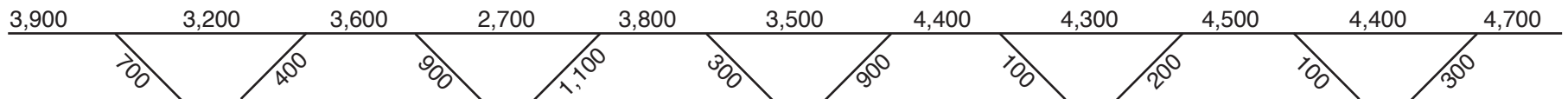

I-93 Southbound: River Road, Andover, to Route 133, Andover PM Peak Period Traffic Flow Diagrams: 2006

Route/Lane Schematic

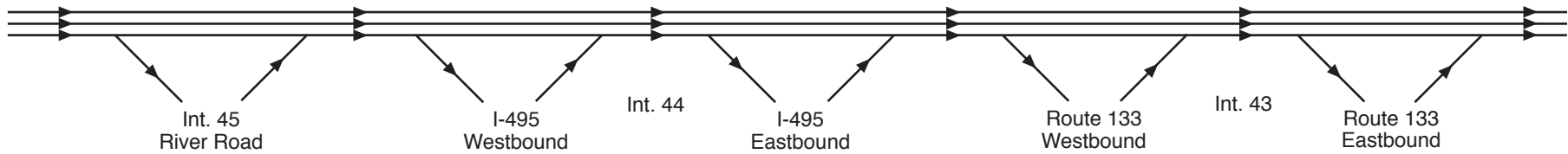

3-4 PM

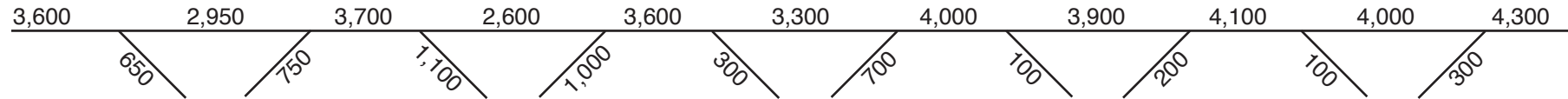

4-5 PM

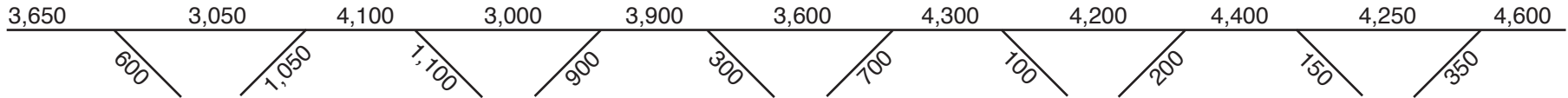

5-6 PM

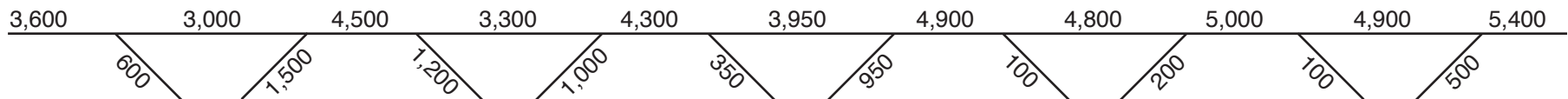

6-7 PM

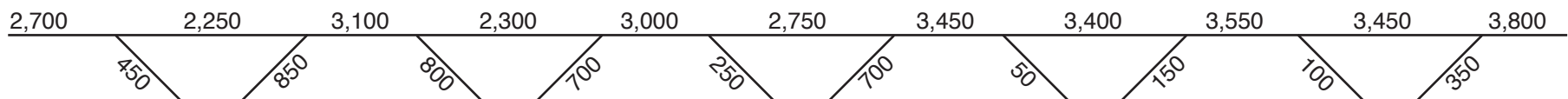

I-93 Northbound: Routes 110 and 113, Methuen, to the New Hampshire State Line AWDT Traffic Flow Diagrams: 1999 & 2006

Route/Lane Schematic

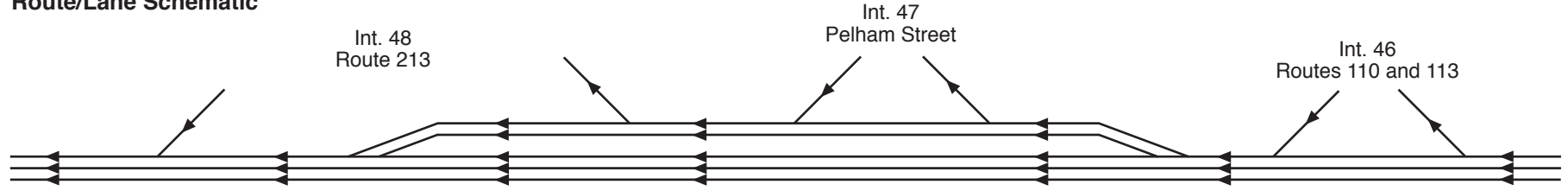

1999 AWDT

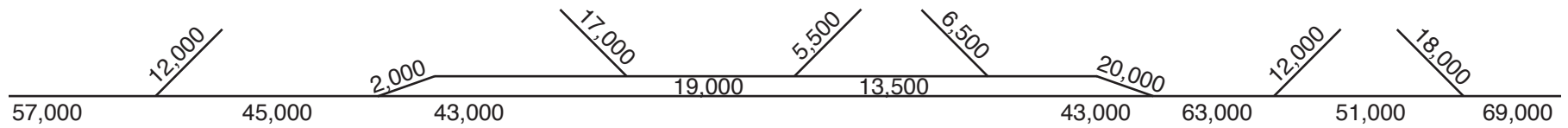

2006 AWDT

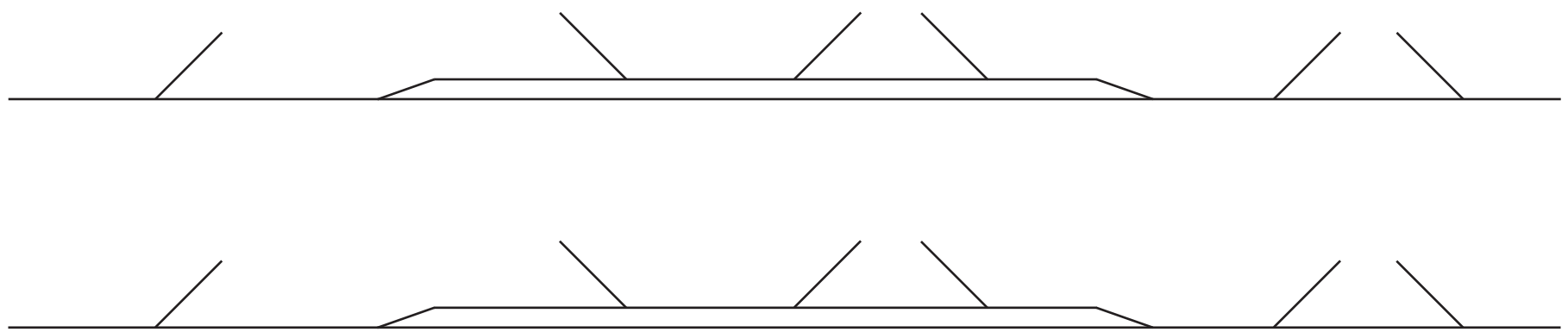
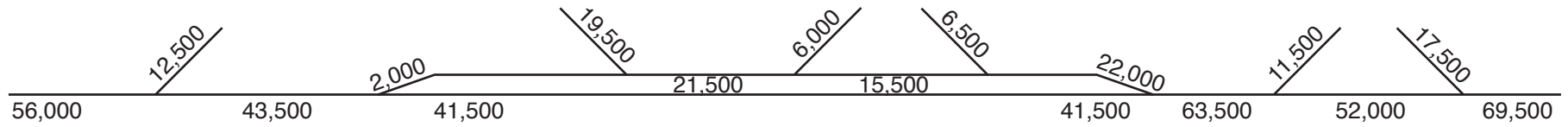

I-93 Northbound: Routes 110 and 113, Methuen, to the New Hampshire State Line AM Peak Period Traffic Flow Diagrams: 2006

Route/Lane Schematic

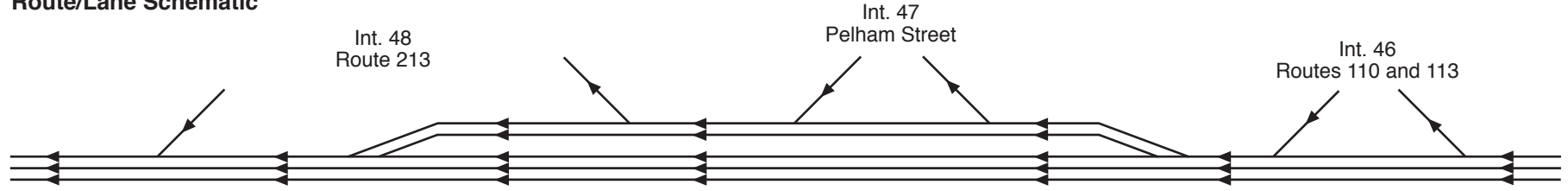

6-7 AM

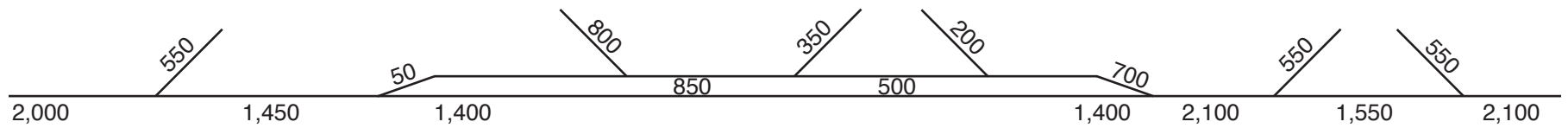

7-8 AM

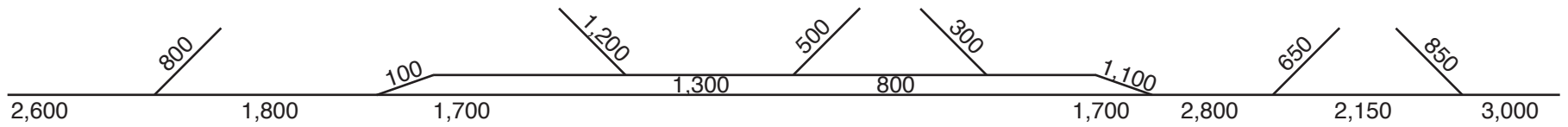

8-9 AM

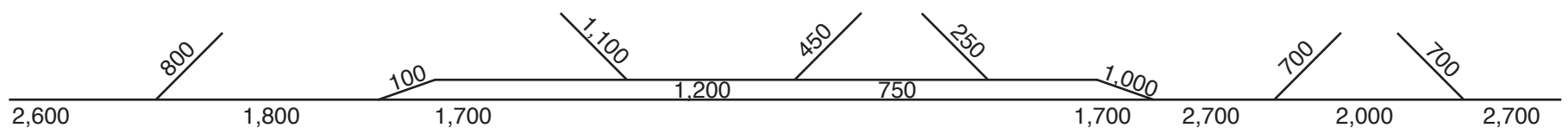

9-10 AM

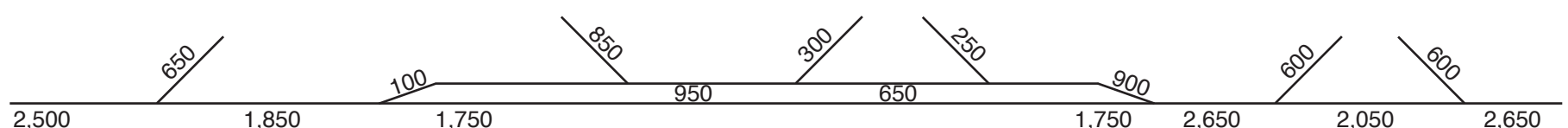

I-93 Northbound: Routes 110 and 113, Methuen, to the New Hampshire State Line PM Peak Period Traffic Flow Diagrams: 2006

Route/Lane Schematic

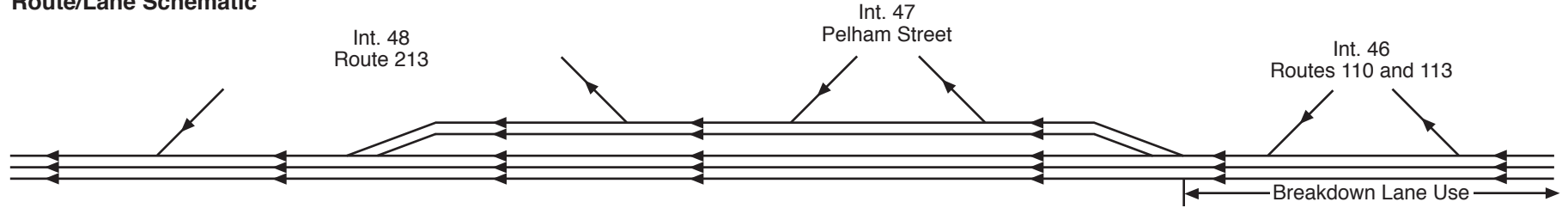

3-4 PM

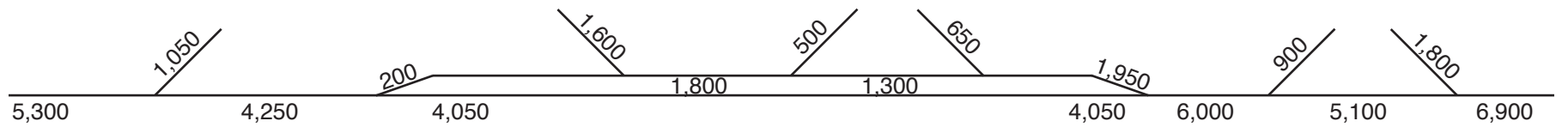

4-5 PM

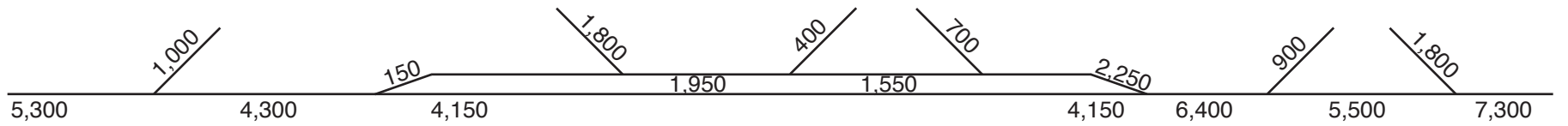

5-6 PM

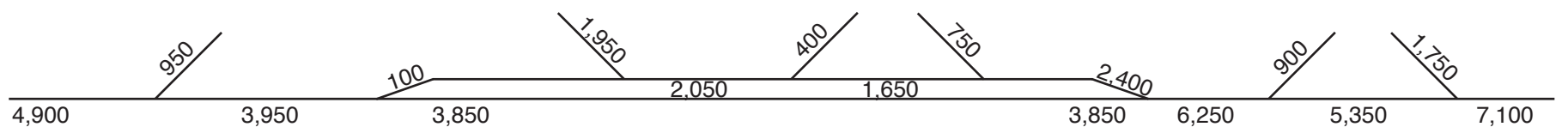

6-7 PM

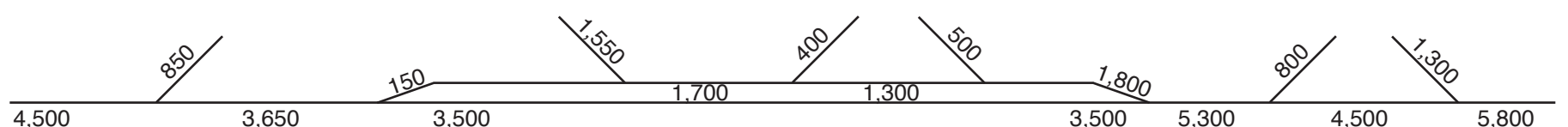

I-93 Southbound: New Hampshire State Line, to Routes 110 and 113, Methuen AWDT Traffic Flow Diagrams: 1999 & 2006

Route/Lane Schematic

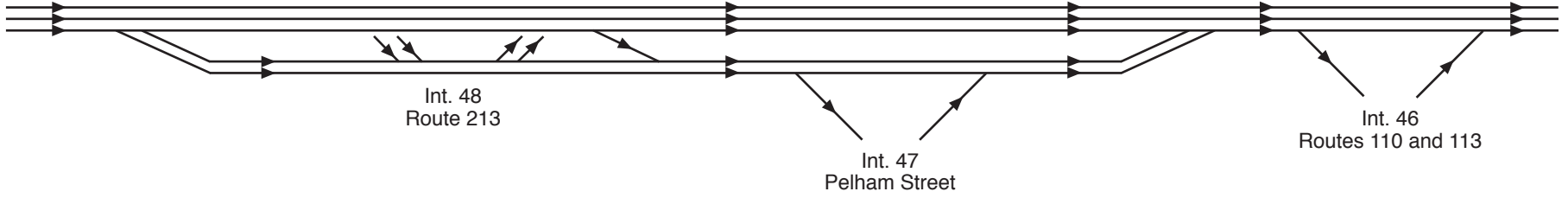

1999 AWDT

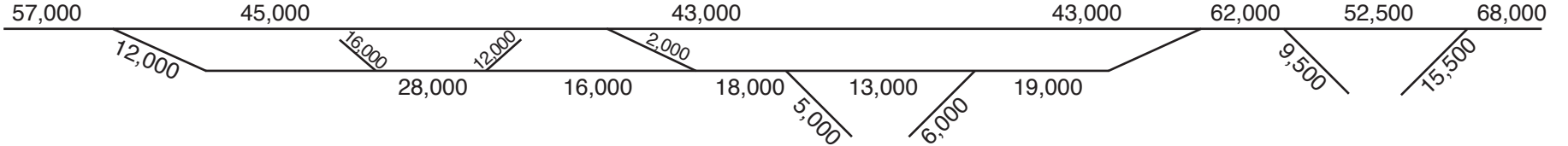

2006 AWDT

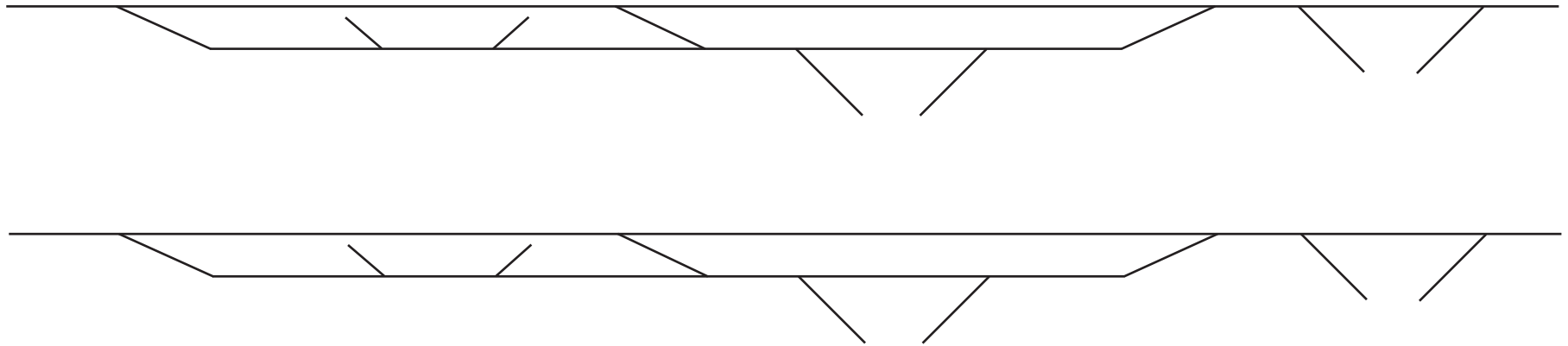
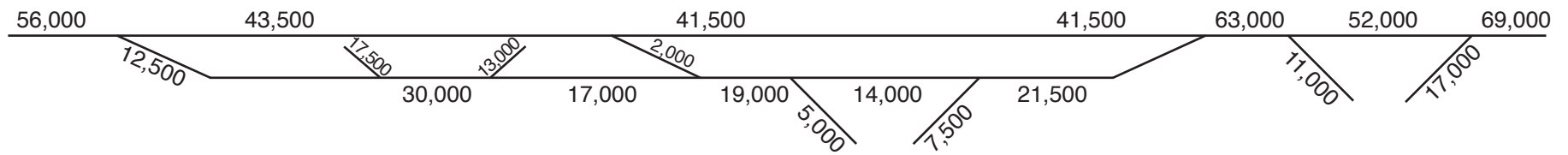

I-93 Southbound: New Hampshire State Line, to Routes 110 and 113, Methuen AM Peak Period Traffic Flow Diagrams: 2006

Route/Lane Schematic

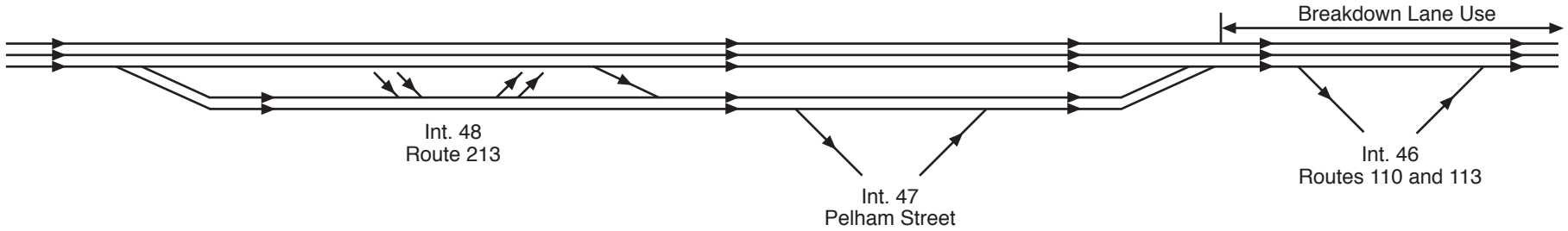

6-7 AM

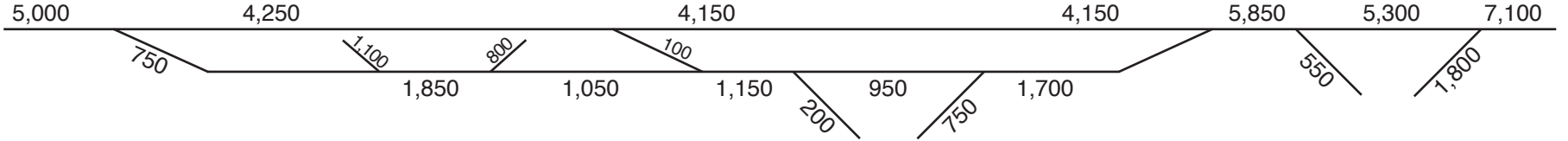

7-8 AM

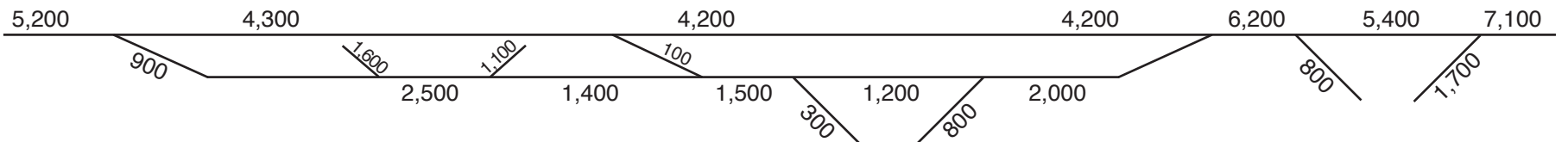

8-9 AM

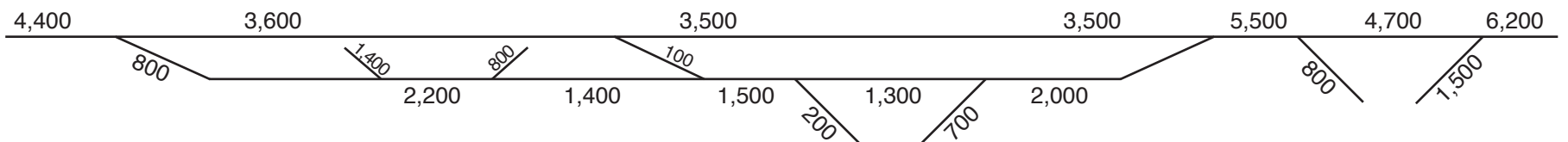

9-10 AM

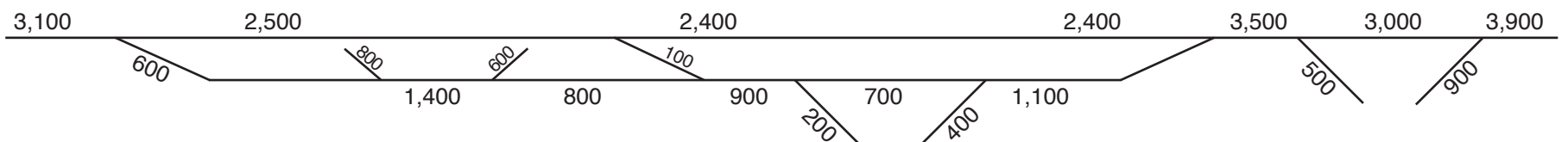

I-93 Southbound: New Hampshire State Line, to Routes 110 and 113, Methuen PM Peak Period Traffic Flow Diagrams: 2006

Route/Lane Schematic

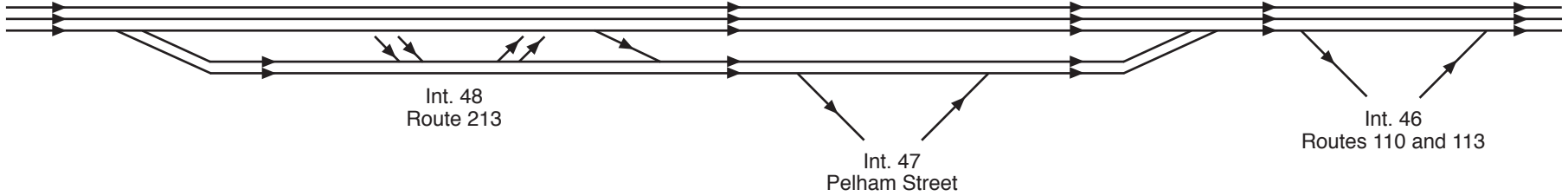

3-4 PM

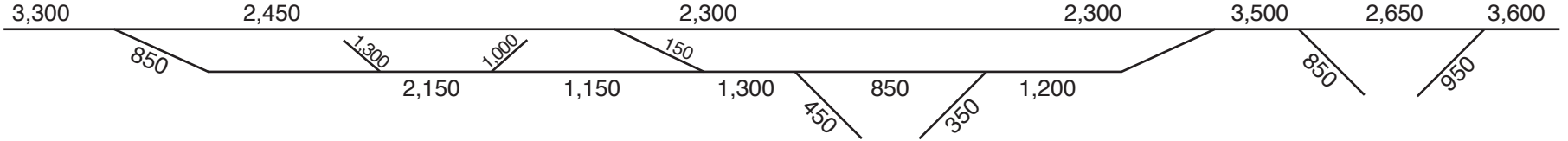

4-5 PM

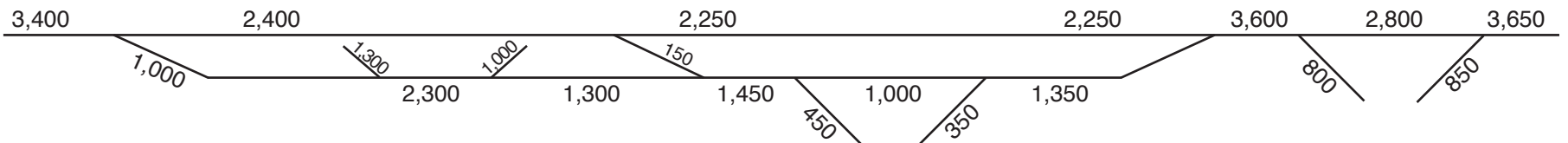

5-6 PM

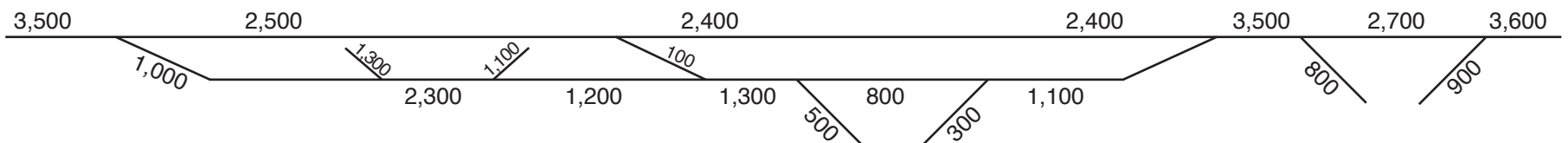

6-7 PM

